

medartis

PRECISION IN FIXATION

SURGICAL TECHNIQUE

CMX Wrist and Forearm



CMX Wrist/Forearm

Contents

3	Introduction
3	Product Materials
3	Intended Purpose
3	Contraindications
3	Color Coding
3	Compatible APTUS Plates and Screws
3	Possible Combination with APTUS Screws
3	Symbols
4	Instrument Application
4	General Instrument Application
4	Drilling
6	Assigning the Screw Length
7	Using the Tap – 2.8 Screws
8	Screw Pick-Up
9	Surgical Techniques
9	CMX APTUS Guide Options
11	Wrist – CMX APTUS Guides with K-Wire Fixation
16	Forearm – CMX APTUS Guides with Screw Fixation
20	Explanation
20	Explanation of the Plate
21	TriLock Locking Technology
21	Correct Application of the TriLock Locking Technology
22	Correct Locking ($\pm 15^\circ$) of the TriLock Screws in the Plate
23	Appendix
23	CMX APTUS Guides and Bone Models

For further information on CMX, visit www.medartis.com.

Introduction

Product Materials

CMX Custom-Made Devices

All CMX APTUS guides and bone models are made of PA12 (polyamide/Nylon 12). The polyamide used is biocompatible for the intended type and time of application during surgery (see "Intended Purpose") and non-toxic in a biological environment.

Compatible APTUS Wrist and Forearm Plates, Screws and Instruments

APTUS implants, plates and screws, are made of pure titanium (ASTM F67, ISO 5832-2) or titanium alloy (ASTM F136, ISO 5832-3). All of the titanium materials used are biocompatible, corrosion-resistant and non-toxic in a biological environment.

K-wires and staples are made of stainless steel (ASTM F138, ASTM F139); instruments are made of stainless steel, PEEK, aluminum, Nitinol or titanium.

Notice

Alongside the CMX APTUS guides, the necessary APTUS screws and the corresponding twist drills as well as the necessary instruments must be available and sterile. These are not included in the CMX delivery.

Intended Purpose

Guides

CMX APTUS guides are intended for use as surgical instruments for guiding purposes when marking, drilling or sawing the bone of a specific patient.

Bone Models

CMX APTUS bone models are intended to illustrate preoperative and/or postoperative anatomical structures of a specific patient.

Contraindications

- Preexisting or suspected infection at or near the implantation site
- Known allergies and/or hypersensitivity to product materials

- Inferior or insufficient bone quality to securely anchor the implant
- Patients who are incapacitated and/or uncooperative during the treatment phase
- Growth plates are not to be blocked with plates and screws

Color Coding

CMX APTUS Guides and Bone Models

CMX APTUS guides and bone models are not color coded.

System Size	Color Code
2.0	Blue
2.5	Purple
2.8	Orange

Plates and Screws

Special implant plates and screws have their own color:

Implant plates blue	TriLock plates (locking)
Implant screws gold	Cortical screws (fixation)
Implant screws blue	TriLock screws (locking)
Implant screws silver	TriLock Express screws (locking)

Compatible APTUS Plates and Screws

Plates and screws can be combined within one system size:

2.5 TriLock Distal Radius Plates

- 2.5 TriLock Screws, HexaDrive 7
- 2.5 Cortical Screws, HexaDrive 7
- 2.5 TriLock Express Screws, HexaDrive 7

2.8 TriLock Radius and Ulna Shaft Plates

- 2.8 Cortical Screws, HexaDrive 7
- 2.8 TriLock Screws, HexaDrive 7

Possible Combination with APTUS Screws

CMX APTUS guides can be combined with the following APTUS screws:

- 2.0 Cortical Screws, HexaDrive 6

Symbols



HexaDrive



See Instructions for Use
www.medartis.com

Instrument Application

General Instrument Application

Drilling

Color-coded twist drills are available for every APTUS system size. All twist drills are color coded with a ring system.

System Size	Color Code
2.0	Blue
2.5	Purple
2.8	Orange

There are two different types of twist drills for every system size: The core hole drills are characterized by one colored ring, the gliding hole drills (for lag screw technique) are characterized by two colored rings.

Hole Drilling for Screws \varnothing 2.0 mm



A-3410



A-3420



A-3430

Core hole drills with \varnothing 1.6 mm = one colored ring

Hole Drilling for Screws \varnothing 2.5 mm



A-3713



A-3723



A-3733

Core hole drills with \varnothing 2.0 mm = one colored ring



A-3711



A-3721



A-3731

Gliding hole drills with \varnothing 2.6 mm = two colored rings

Hole Drilling for Screws \varnothing 2.8 mm



A-3832

Core hole drill with \varnothing 2.35 mm = one colored ring



A-3834

Gliding hole drill with \varnothing 2.9 mm = two colored rings

Warning

For 2.0 screws the twist drill must always be guided through the drill guide (A-2020).



A-2020
2.0/2.3 Drill Guide, Centric/Excentric

For 2.5 screws the twist drill must always be guided through the drill guide (A-2026).



A-2026
2.5/2.8 Drill Guide, TriLock^{PLUS}

For 2.8 screws the twist drill must always be guided through the drill guide (A-2026 or A-2820).



A-2820
2.8 Drill Guide

Using the drill guide prevents damage to the screw hole and protects the surrounding tissue from direct contact with the drill. The drill guide also serves to limit the pivoting angle.

This symbol marks the end of the drill guide A-2020 used for centric drilling. This end is used for all 2.0 fixation holes.



The end with one orange marking of the double-ended drill guide (A-2820) can be used for all 2.5/2.8 screw holes and for the insertion of independent screws (e.g. fragment fixation with screws alone). The other end marked with "LAG" is used for drilling a gliding hole only.

The one end of the double-ended drill guide for TriLock^{PLUS} (A-2026) can be used for all 2.5/2.8 screw holes. The other end marked with the arrow is used for the TriLock^{PLUS} holes only.

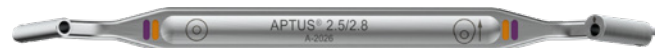

A-2026
2.5/2.8 Drill Guide, TriLock^{PLUS}

Notice

The double-ended drill guide for lag screws (A-2721) is used only to perform the classic lag screw technique according to AO/ASIF.



A-2721
2.5 Drill Guide for Lag Screws

Warning

For TriLock plates ensure that the screw holes are predrilled with a pivoting angle of no more than ±15°. For this purpose, the drill guides feature a limit stop of ±15°. A predrilled pivoting angle of >15° no longer allows the TriLock screws to correctly lock in the plate.



Assigning the Screw Length

The depth gauge (A-2031, A-2730) is used to assign the ideal screw length for use in monocortical or bicortical screw fixation of TriLock screws and cortical screws.



A-2031
2.0–2.8 Depth Gauge



A-2730
2.5 Depth Gauge

Retract the slider of the depth gauge. The depth gauge caliper has a hooked tip that is either inserted to the bottom of the hole or is used to catch the far cortex of the bone. When using the depth gauge, the caliper stays static, only the slider is adjusted.



To assign the screw length, place the distal end of the slider onto the implant plate or directly onto the bone (e.g. for fracture fixation with lag screws).

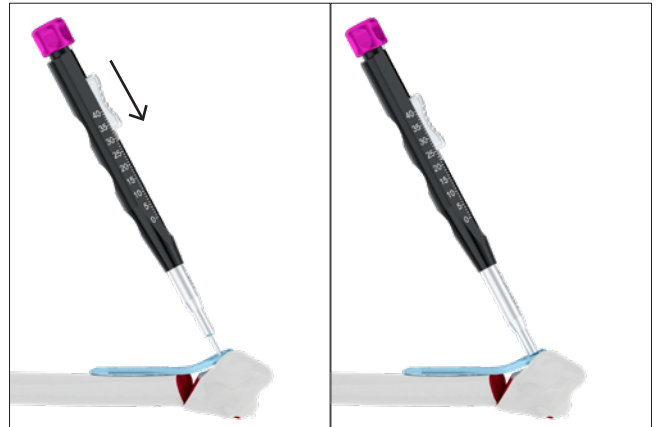

The ideal screw length for the assigned drill hole can be read on the scale of the depth gauge.

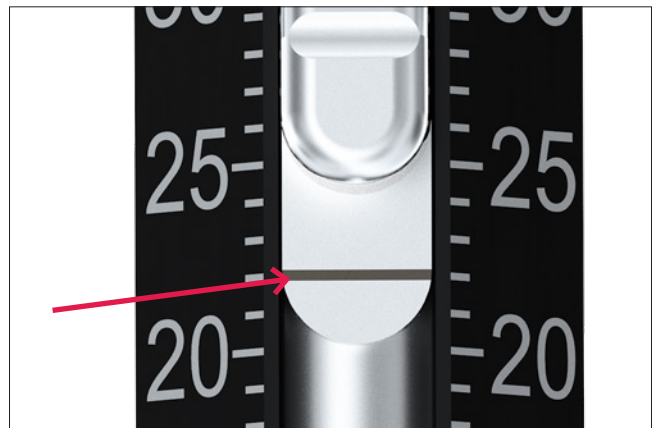

Using the Tap – 2.8 Screws

Thread Preparation with the Tap

Caution

All APTUS screws are self-tapping. In case of very hard bone, especially in the shaft region of the radius or ulna, it may be necessary to use the 2.8 tap (A-3839) to reduce the insertion torque of the 2.8 mm screws.



A-3839
2.8 Tap



A-2077
Handle with Quick Connector, AO

After drilling a core hole with the core hole drill (A-3832, one orange ring), create a thread for the screw using the 2.8 tap (A-3839) together with the handle (A-2077).

Assign the screw length and insert the corresponding screw with the screwdriver (screwdriver blade A-2013 with handle A-2077).

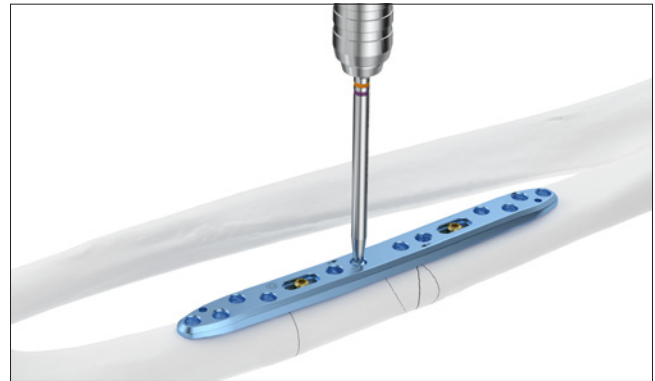

Screw Pick-Up

The screwdrivers (A-2610 and A-2710) and the screwdriver blades (A-2611 and A-2013) feature the patented HexaDrive self-holding system.



2.0 screws

For 2.0 screws, use the screwdriver A-2610 or attach the blue/brown color coded 2.0/2.3 screwdriver blade (A-2611) to the handle with quick connector A-2073.

2.5 screws

For 2.5 screws, use the screwdriver A-2710 or attach the purple/orange color coded 2.5/2.8 screwdriver blade (A-2013) to the handle with quick connector A-2073.

2.8 screws

For 2.8 screws, attach the purple/orange color coded 2.5/2.8 screwdriver blade (A-2013) to the handle with quick connector A-2077.

To remove the screws from the implant container, insert the appropriately color-coded screwdriver perpendicularly into the screw head of the desired screw and pick up the screw with axial pressure.

Notice

The screw will not hold without axial pressure.

Caution

Vertically extract the screw from the compartment. Picking up the screw repeatedly may lead to permanent deformation of the self-retaining area of the HexaDrive inside the screw head. Therefore, the screw may no longer be able to be picked up correctly. In this case, a new screw has to be used.

Notice

Check the screw length and diameter at the scale of the measuring module. The screw length is determined at the end of the screw head.



A-2610
2.0/2.3 Screwdriver, HD6, Self-Holding



A-2710
2.5 Screwdriver, HD7, Self-Holding



A-2611
2.0/2.3 Screwdriver Blade, HD6, AO



A-2013
2.5/2.8 Screwdriver Blade, HD7, AO



A-2073
Handle with Quick Connector, AO



A-2077
Handle with Quick Connector, AO

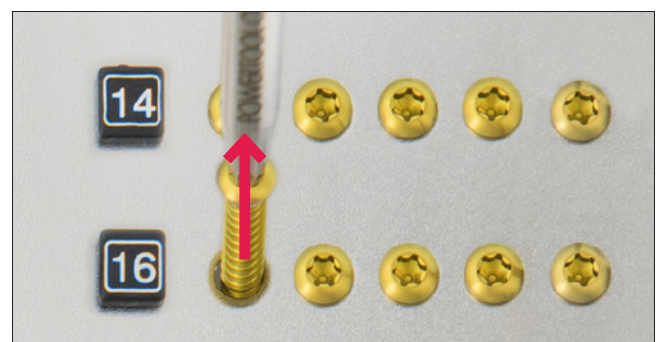
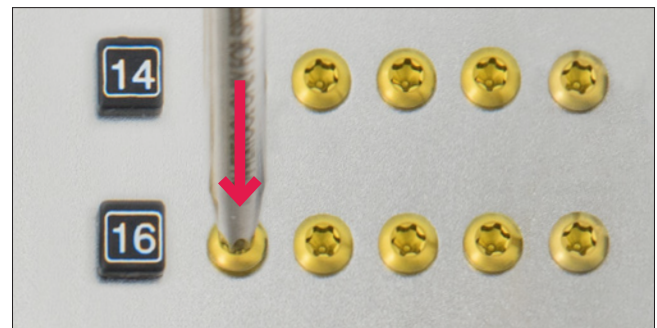

Surgical Techniques

CMX APTUS Guide Options

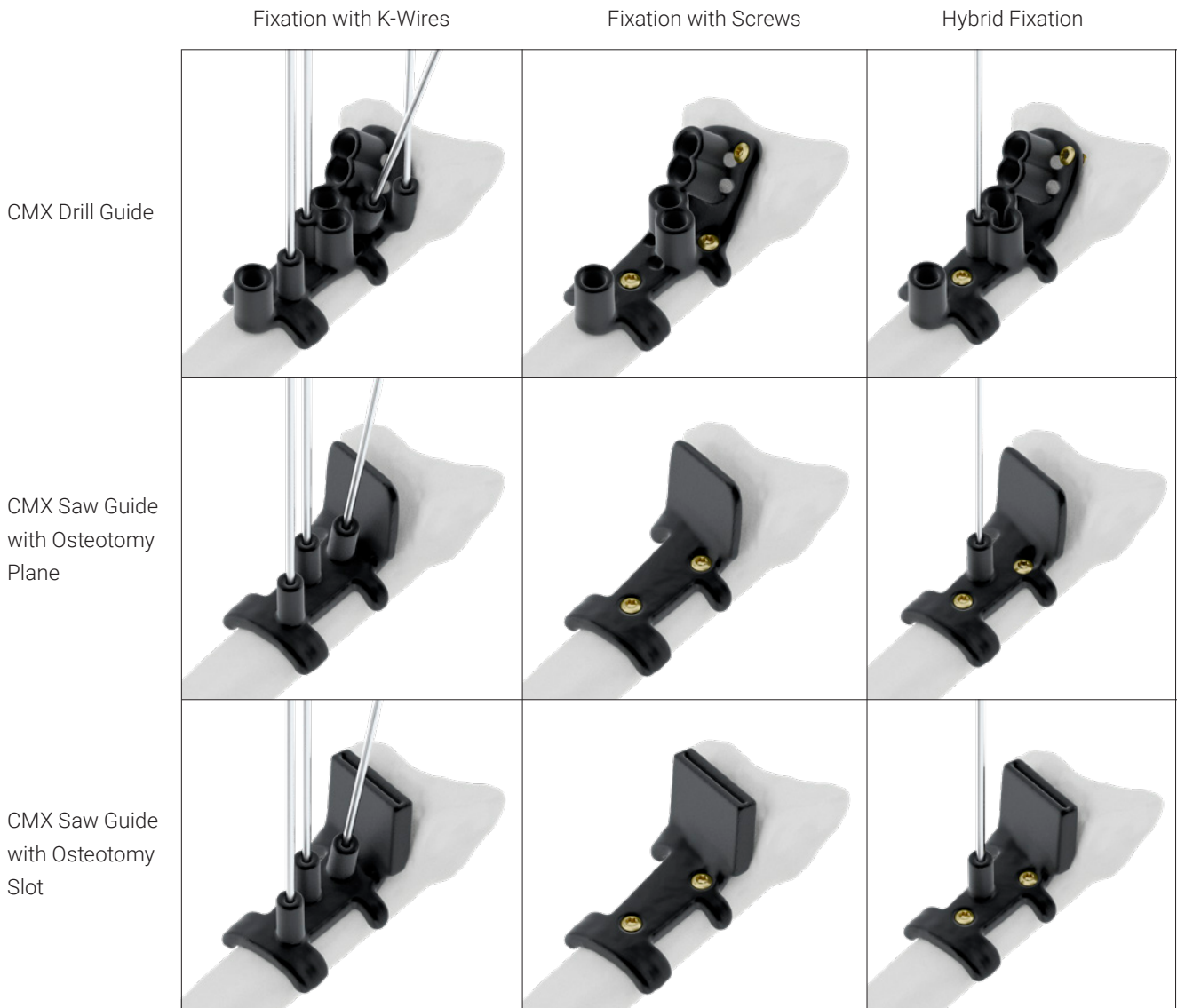

The CMX APTUS guides can be fixed in the designated holes with K-wires or 2.0 cortical screws. Please refer to the case-specific design freeze document for further details.



Wrist – CMX APTUS Guides with K-Wire Fixation

Placing and fixing the CMX drill guide

Before placing the CMX drill guide on the bone, ensure that the bone is fully exposed to ensure an optimum contact surface.

Caution

The CMX drill guide itself features orientation markings. Additionally, there are consecutive numberings in case more than one CMX drill guide is needed. These must be taken into account when using the guide. Please refer to the case-specific design freeze document for further details.

To identify the previously defined position of the CMX drill guide on the bone, it should be placed in various positions. The correct position can be determined based on the fit with the bone or by using the bone model as a reference. Illustrations are provided in the case-specific design freeze document as a guide.

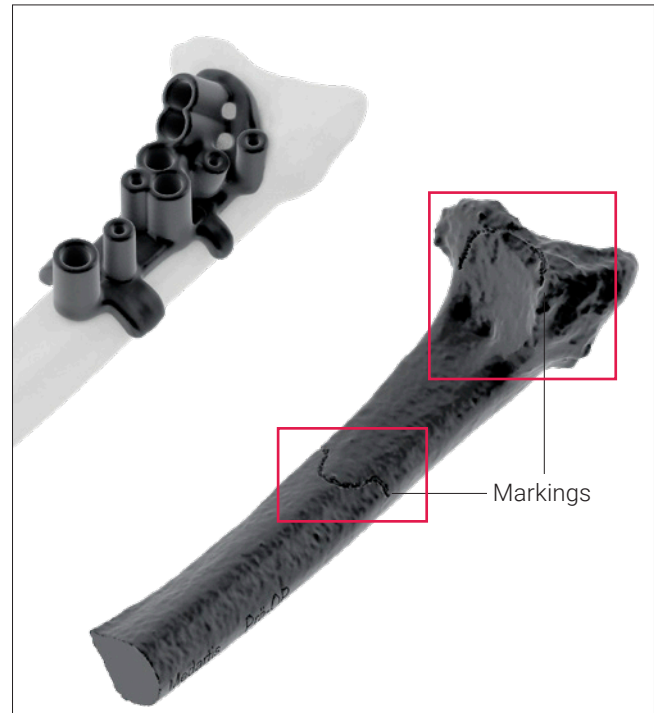

Once the defined position is found, the CMX drill guide is fixed in the designated holes (1) with K-wires (A-5040.41, A-5042.41) according to the case-specific design freeze document.

Caution

Irrigation ports (2) must not be used to fix the guide.



Caution

Throughout the application it is important to ensure that no excess force is applied to the product as this could cause damage.

Drilling the screw holes for the plate

After the CMX drill guide is safely fixed to the bone, all predefined screw holes are drilled. Use the drill guide (A-2026) and the APTUS twist drill (A-3713, A-3723, A-3733) for core diameter 2.0 mm (one purple ring). This helps to ensure precise drilling of the holes and to reduce abrasion.

The irrigation ports are used for rinsing and cooling during the drilling process.



Removing the CMX drill guide

Remove the K-wires except of the parallel ones defined in the case-specific design freeze document and remove the CMX drill guide.

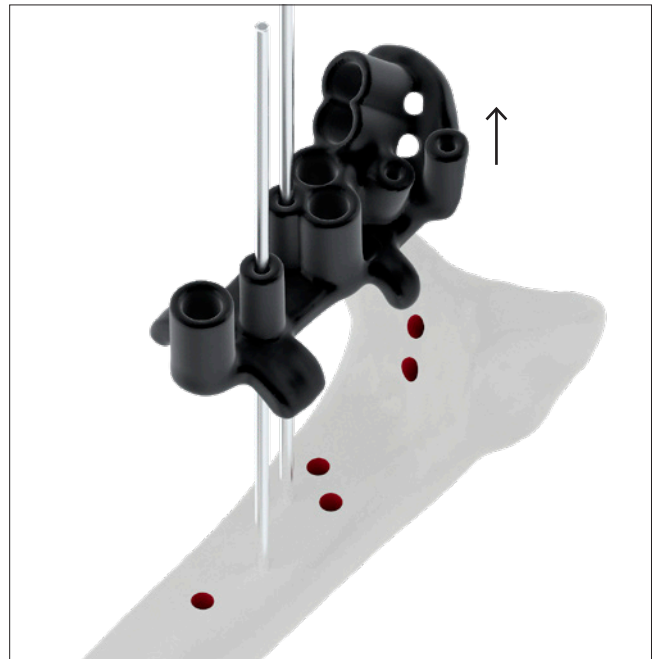

Placing and fixing the CMX saw guide

The parallel K-wires support to identify the defined position. The CMX saw guide is fixed in the designated holes with at least one additional K-wire (A-5040.41, A-5042.41) according to the case-specific design freeze document.

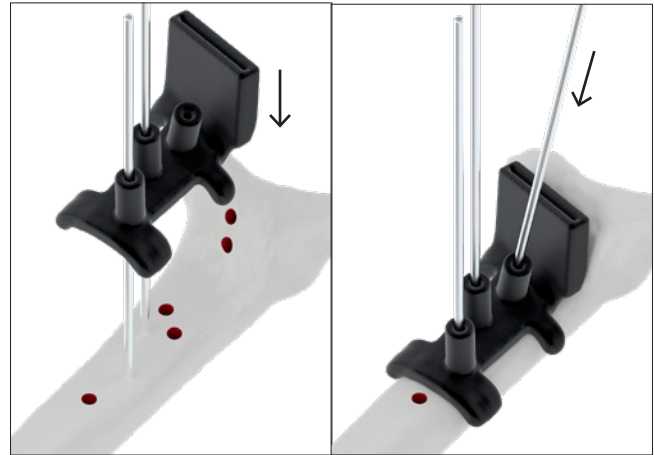

Osteotomy of the near cortex

After the CMX saw guide is safely fixed to the bone, the osteotomy of the near cortex is performed.

Caution

To ensure a precise osteotomy, the saw blade must have the minimum dimensions:

Thickness: 0.40 mm Width: ~10 mm Cutting length: ~30 mm

Caution

Avoid drilling or sawing into the guide as this can cause abrasion on the guide. The abrasive material should not enter the tissue. The surgical site must be thoroughly flushed during and after drilling and sawing and any particles must be suctioned away.

The guide may not be adapted either before or during surgery.



Removing the CMX saw guide and finalizing the osteotomy

Remove the K-wires and the CMX saw guide.

Complete the planned osteotomy.



Fixing the plate

Assign the screw length using the depth gauge (A-2730) in the predrilled distal holes and insert 2.5 TriLock screws (A-5750.xx). Perform the final fixation of the plate in the remaining distal holes with 2.5 TriLock screws.

The distal fragment is reduced by aligning the proximal end of the plate shaft.

Repeat these steps with the remaining predrilled proximal plate holes. Drill, assign the screw length and insert a 2.5 cortical screw (A-5700.xx) into the oblong hole.

Drill, assign the screw length and fill the remaining screw holes with 2.5 TriLock screws (A-5750.xx).

Warning

Depending on the level of correction, some cases may require bone grafting between the proximal and the distal fragments, autologous bone is recommended. Insufficient bone grafting can increase the risk of breakage of the plate.



Optionally – Using Express Screws for reposition

Place the plate on the bone model with two parallel predrilled holes and insert two 2.5 TriLock Express screws (A-5755.xx) into the predefined distal plate holes. Please refer to the case-specific design freeze document for further details.



Remove the plate with the locked 2.5 TriLock Express screws from the bone model.

Drill the gliding hole using the APTUS twist drill marked with two purple rings (A-3711, A-3721, A-3731, Ø 2.6 mm) in combination with the end of the drill guide (A-2721) labeled with two purple bars to open up the cortex for the thread in the neck of the 2.5 TriLock Express screws.



Notice

Do not drill further than the near cortex.

Insert the 2.5 TriLock Express screws into the predrilled distal holes. Perform the final fixation of the plate in the remaining distal holes with 2.5 TriLock screws (A-5750.xx).

The distal fragment is reduced by aligning the proximal end of the plate shaft.



Complete the fixation of the plate shaft with screws of which at least one should be a 2.5 TriLock screw (distally to the oblong hole).



Warning

Insert at least three TriLock screws into the most distal row and two TriLock screws into the second distal row.

Forearm – CMX APTUS Guides with Screw Fixation

Placing and fixing the CMX drill guide

Before placing the CMX drill guide on the bone, ensure that the bone is fully exposed to ensure an optimum contact surface.

Caution

The guide itself features orientation markings. These must be taken into account when using the guide. Please refer to the case-specific design freeze document for further details.

To identify the previously defined position of the CMX drill guide on the bone, it should be placed in various positions. The correct position can be determined based on the fit with the bone or by using the bone model as a reference. Illustrations are provided in the case-specific design freeze document as a guide.

Once the defined position is found, the CMX drill guide is fixed in the designated holes (1) with 2.0 cortical screws (A-5400.xx). Use the drill guide (A-2020) and the APTUS twist drill (A-3410, A-3420, A-3430) for core diameter 1.6 mm (one blue ring) to drill the fixation holes. This helps to ensure precise drilling of the holes and to reduce abrasion. Assign the screw length using the depth gauge (A-2031) and insert 2.0 cortical screws (A-5400.xx).

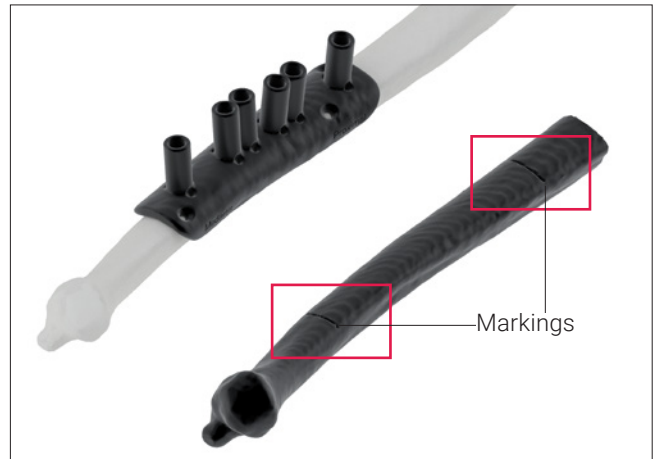

Caution

Irrigation ports (2) must not be used to fix the guide.

Caution

Throughout the application it is important to ensure that no excess force is applied to the product as this could cause damage.

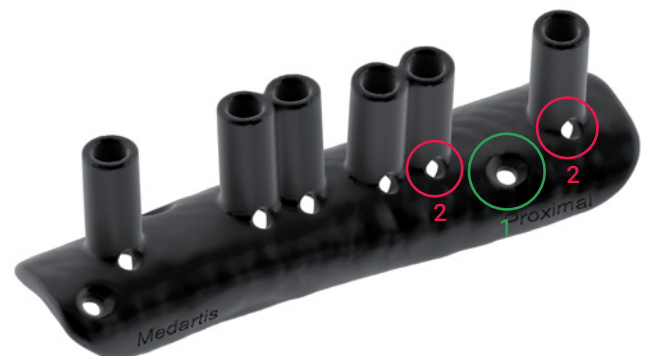

Drilling the screw holes for the plate

After the CMX drill guide is safely fixed to the bone, all predefined screw holes are drilled. Use the drill guide (A-2026) and the APTUS twist drill (A-3832) for core diameter 2.35 mm (one orange ring). This helps to ensure precise drilling of the holes and to reduce abrasion.

The irrigation ports are used for rinsing and cooling during the drilling process.



Removing the CMX drill guide

Remove the 2.0 cortical screws (A-5400.xx) and the CMX drill guide.



Placing and fixing the CMX saw guide

Fix the CMX saw guide with 2.0 cortical screws (A-5400.XX). Use the same holes and screw length which were used to fix the CMX drill guide.

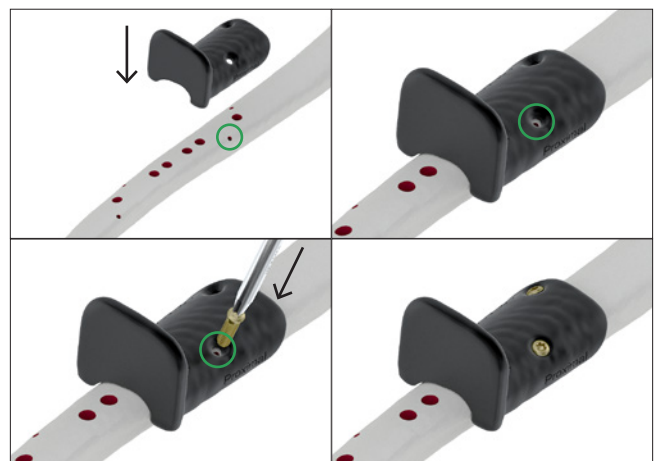

Osteotomy of the near cortex

After the CMX saw guide is safely fixed to the bone, the osteotomy is performed.

Caution

To ensure a precise osteotomy, the saw blade must have the minimum dimensions:

Thickness: 0.40 mm Width: ~10 mm Cutting length: ~30 mm

Caution

Avoid drilling or sawing into the guide as this can cause abrasion on the guide. The abrasive material should not enter the tissue. The surgical site must be thoroughly flushed during and after drilling and sawing and any particles must be suctioned away. The guide may not be adapted either before or during surgery.

Removing the CMX saw guide and finalizing the osteotomy

Remove the 2.0 cortical screws and the CMX saw guide.

Complete the planned osteotomy.

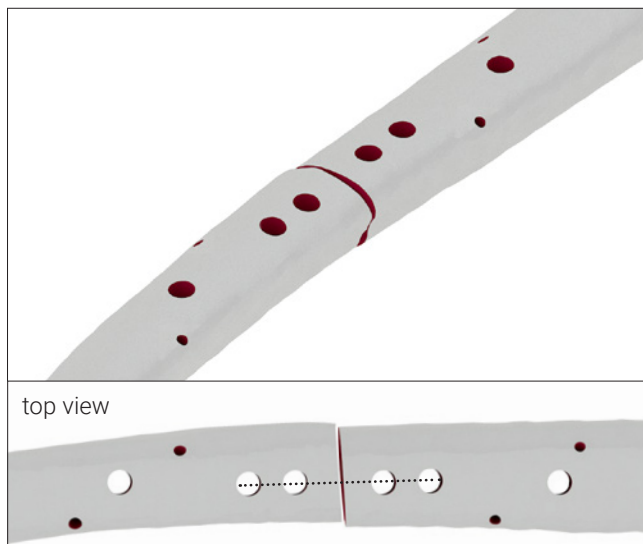
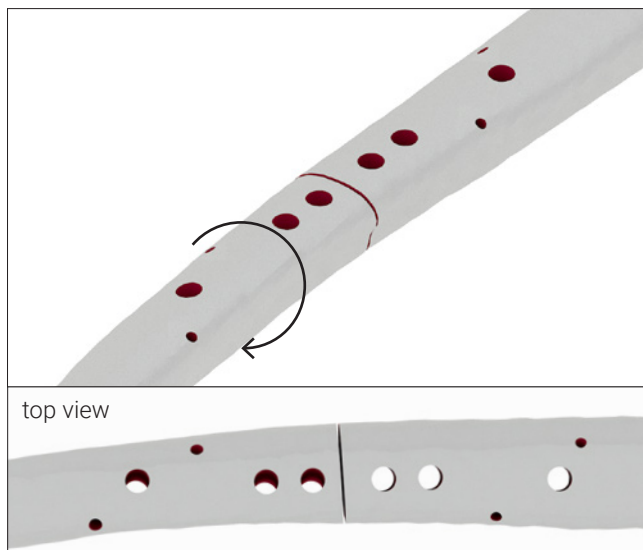

Reposition:

The correct reposition is reached when the predrilled holes are congruent with the holes of the plate.

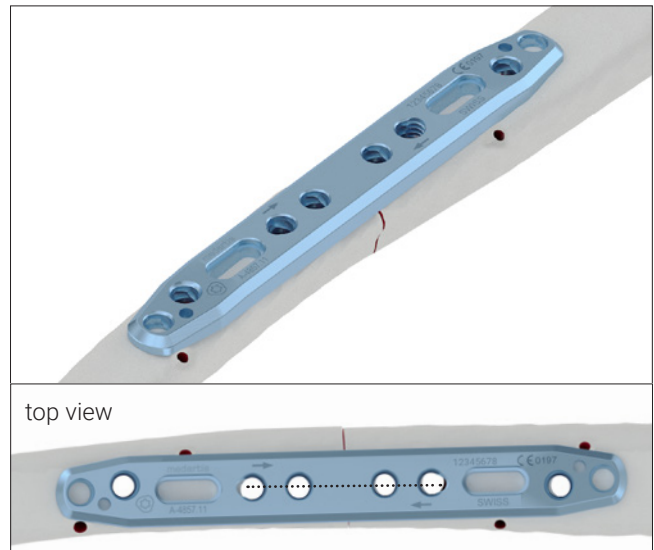
**Fixing the plate**

Assign the screw length using the depth gauge (A-2031) in the predrilled holes and insert the 2.8 TriLock screws (A-5850.xx). Drill, assign the screw length and fill the remaining screw holes with 2.8 TriLock screws (A-5850.xx).

**Warning**

Depending on the level of correction, some cases may require bone grafting between the proximal and the distal fragments, autologous bone is recommended. Insufficient bone grafting can increase the risk of breakage of the plate.

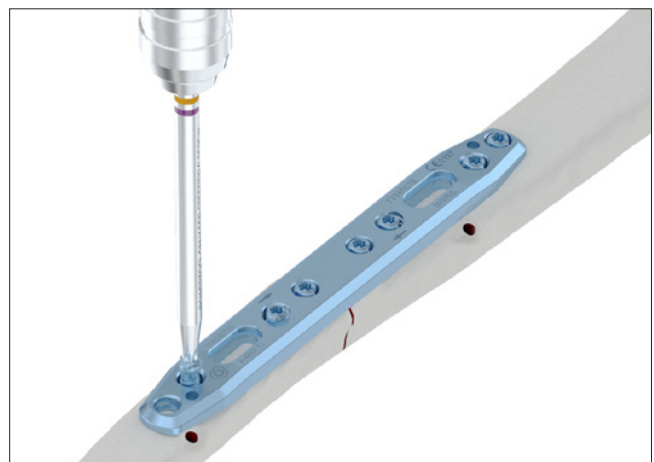

Explantation

Explantation of the Plate

1. Removing the screws

Unlock all screws and remove them.

The order in which the screws are removed is not relevant.

In case the plate sticks to the bone, use a periosteal elevator to carefully lift and detach it from the bone.

Caution

When removing the screws, ensure that any bone ingrowth in the screw head has been removed, that the screwdriver/screw head connection is aligned in axial direction, and that a sufficient axial force is used between blade and screw.

TriLock Locking Technology

Correct Application of the TriLock Locking Technology

The screw is inserted through the plate hole into a predrilled canal in the bone. An increase of the tightening torque will be felt as soon as the screw head gets in contact with the plate surface.

This indicates the start of the “Insertion Phase” as the screw head starts entering the locking zone of the plate (section “A” in the diagram). Afterwards, a drop of the tightening torque

occurs (section “B” in the diagram). Finally the actual locking is initiated (section “C” in the diagram) as a friction connection is established between screw and plate when tightening firmly.

The torque applied during fastening of the screw is decisive for the quality of the locking as described in section “C” of the diagram.

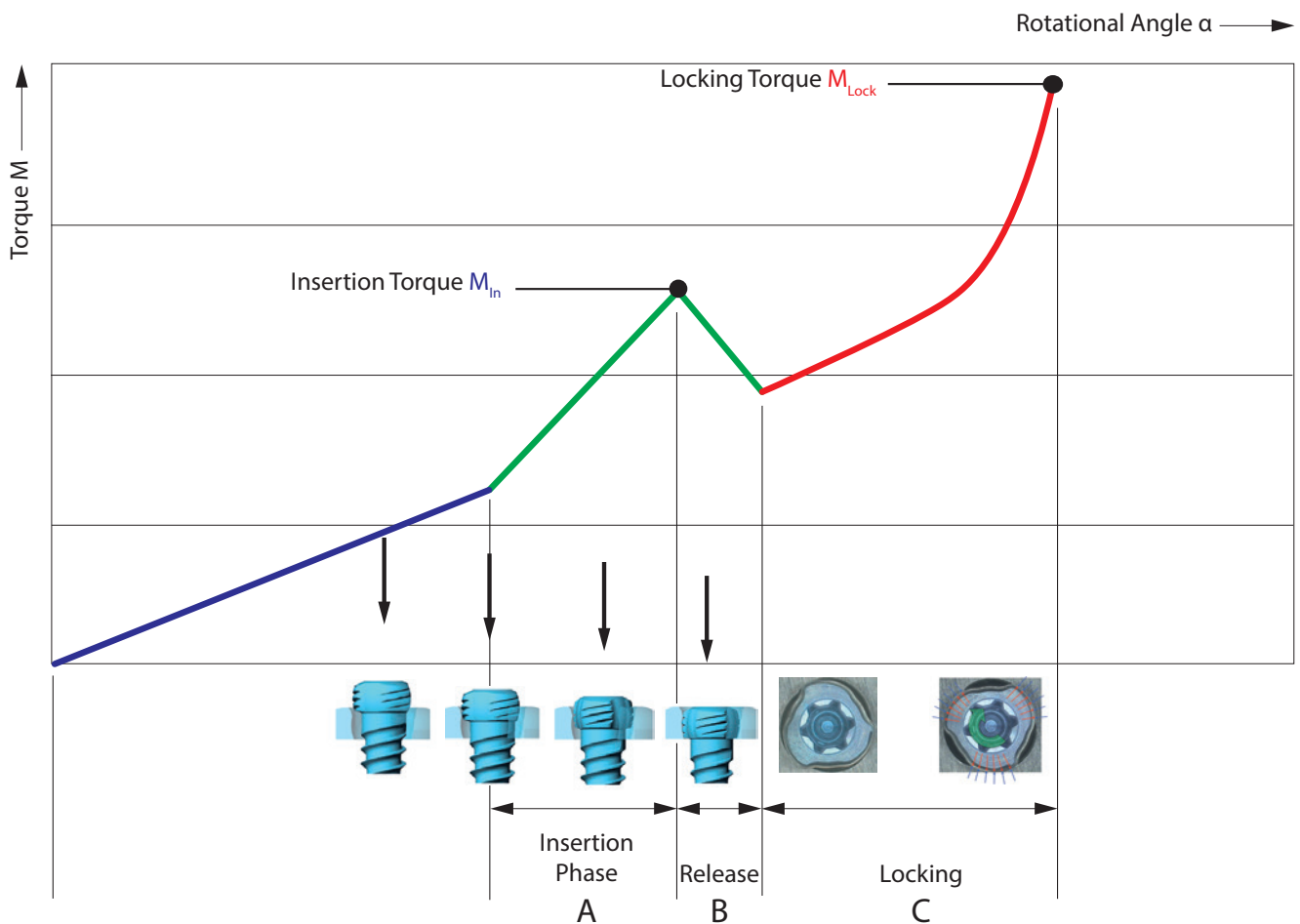

Correct Locking ($\pm 15^\circ$) of the TriLock Screws in the Plate

The example below representatively depicts the correct locking position of a 2.5 mm screw in a straight 1.6 mm thick plate. Correct locking occurs only when the screw head is locked flush with the locking contour (fig. 1 and 3).

However, if there is still a noticeable protrusion (fig. 2 and 4), the screw head has not completely reached the locking position. In this case, the screw has to be retightened to

obtain full penetration and proper locking. In case of poor bone quality, a slight axial pressure might be necessary to achieve proper locking.

After having reached the locking torque (M_{Lock}), do not further tighten the screw, otherwise the locking function cannot be guaranteed anymore.

Correct: LOCKED

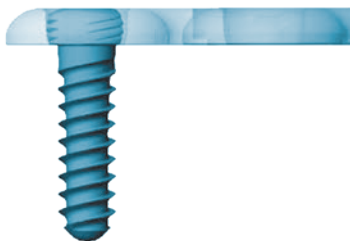

Figure 1

Incorrect: UNLOCKED

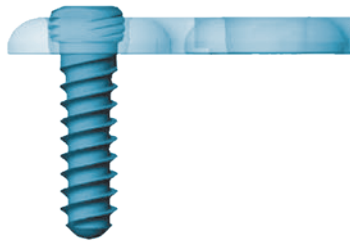

Figure 2

Correct: LOCKED



Figure 3

Incorrect: UNLOCKED

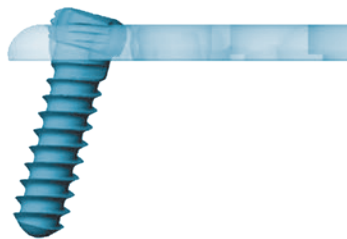

Figure 4

Appendix

CMX APTUS Guides and Bone Models

For all CMX APTUS guides, bone models and compatible APTUS Wrist and Forearm plates, screws and instruments according to the case-specific design freeze document, see CMX Portal at cmx.medartis.com.

R_CMX-WRIST-FOREARM-01010001_v1 / © 2022-09, Medartis AG, Switzerland. All technical data subject to alteration.

MANUFACTURER & HEADQUARTERS

Medartis AG | Hochbergerstrasse 60E | 4057 Basel / Switzerland

P +41 61 633 34 34 | F +41 61 633 34 00 | www.medartis.com

SUBSIDIARIES

Australia | Austria | Brazil | France | Germany | Japan | Mexico | New Zealand | Poland | Spain | UK | USA

For detailed information regarding our subsidiaries and distributors, please visit www.medartis.com

CE CE
0197

UK UK
CA CA
0086

Disclaimer: This information is intended to demonstrate the Medartis portfolio of medical devices. A surgeon must always rely on her or his own professional clinical judgement when deciding whether to use a particular product when treating a particular patient. Medartis is not giving any medical advice. The devices may not be available in all countries due to registration and/or medical practices. For further questions, please contact your Medartis representative (www.medartis.com). This information contains products with CE and/or UKCA marking. All pictures shown are for illustration purposes only and may not be an exact representation of the product. For US only: Federal law restricts this device to sale by or on the order of a physician.