

SURGICAL TECHNIQUE

Ulna Shortening System 2.5

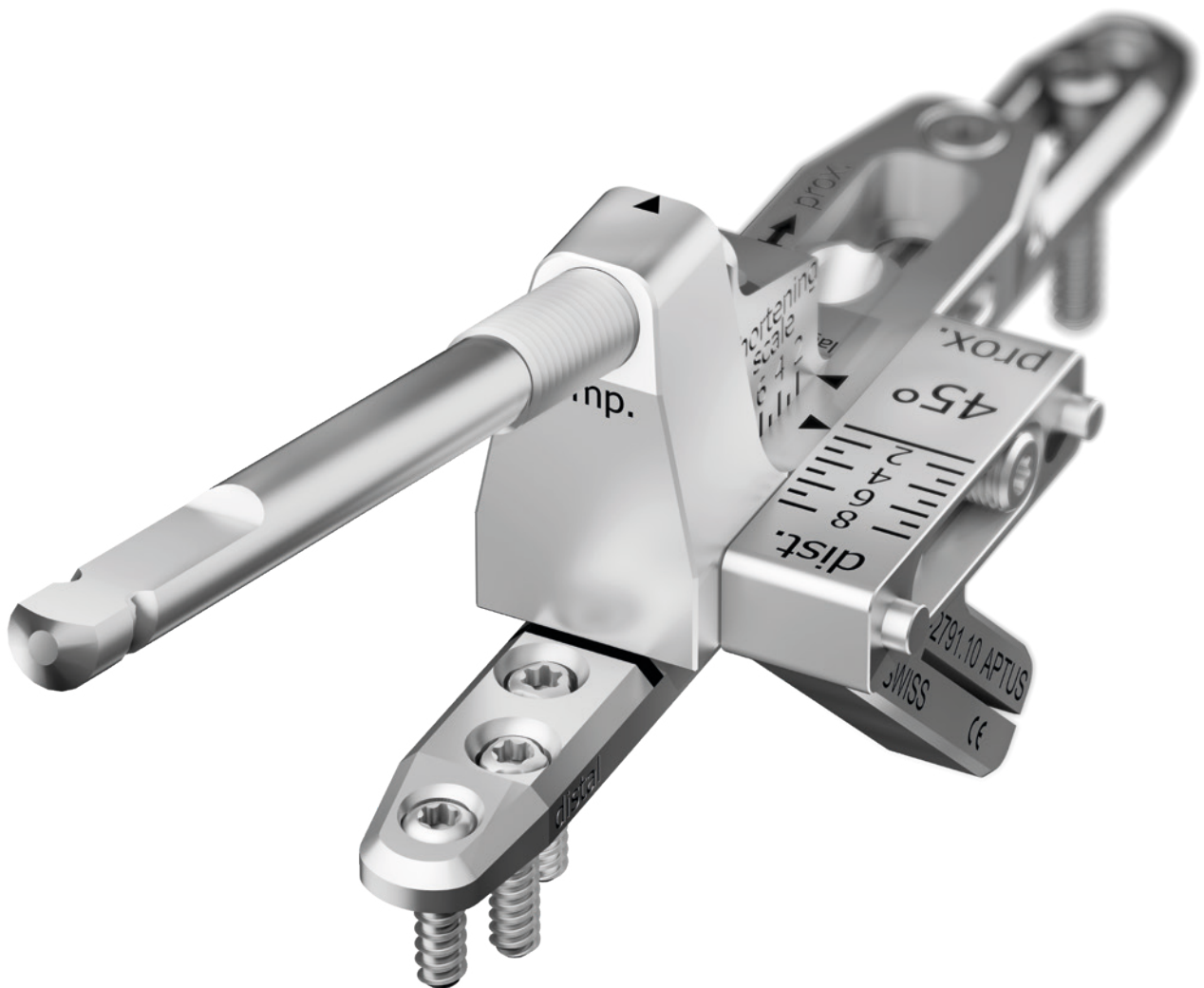

Contents

3	Introduction
	Product Materials
	Indications
	Contraindications
	Specific Complications
	Color Coding
	Symbols
4	System Overview
5	Instrument Application
	General Instrument Application
	Drilling
6	Assigning the Screw Length
7	Screw Pick-Up
8	Surgical Techniques
	General Surgical Techniques
	Lag Screw Technique
9	Specific Surgical Techniques
	Ulna Shortening with Saw Guide 45°
14	Ulna Shortening with Saw Guide 90°
19	Explantation
20	TriLock Locking Technology
	Correct Application of the TriLock Locking Technology
21	Correct Locking ($\pm 15^\circ$) of the TriLock Screws in the Plate
22	Implants, Instruments and Containers

For further information regarding the APTUS product line visit www.medartis.com

Introduction

Product Materials

Product	Material
Plates	Pure titanium, titanium alloy
Screws	Titanium alloy
Staples and K-wires	Stainless steel
Instruments	Stainless steel, PEEK, aluminum, Nitinol, silicone or titanium
Container	Stainless steel, aluminum, peek, polyphenylsulfone, polyurethane, silicone

Indications

APTUS Wrist

- Fractures, osteotomies and arthrodesis of the bones of the wrist

Ulna Shortening plate

- Osteotomies of the ulna

Contraindications

- Pre-existing or suspected infection at or near the implantation
- Known allergies and / or hypersensitivity to implant materials
- Inferior or insufficient bone quality to securely anchor the implant
- Patients who are incapacitated and/or uncooperative during the treatment phase
- Growth plates are not to be blocked with plates and screws

Specific Complications

Specific complications that may be associated with the Ulna Shortening System include:

- Non-union/pseudoarthrosis
- Delayed union

Delayed union and/or non-union/pseudoarthrosis might be promoted due to patient's overall state of health and/or lifestyle.

Potential risk factors contributing to complications include:

- Age
- Malnutrition
- Smoking
- Alcohol abuse

Color Coding

System Size	Color Code
2.5	Purple

Plates and Screws

Special implant plates and screws have their own color:

Implant plates blue	TriLock plates (locking)
Implant screws gold	Cortical screws (fixation)
Implant screws blue	TriLock screws (locking)

Symbols



HexaDrive



System Overview

The saw guides are available in a 45° and a 90° design. Both options are compatible with the Ulna Shortening System 2.5.

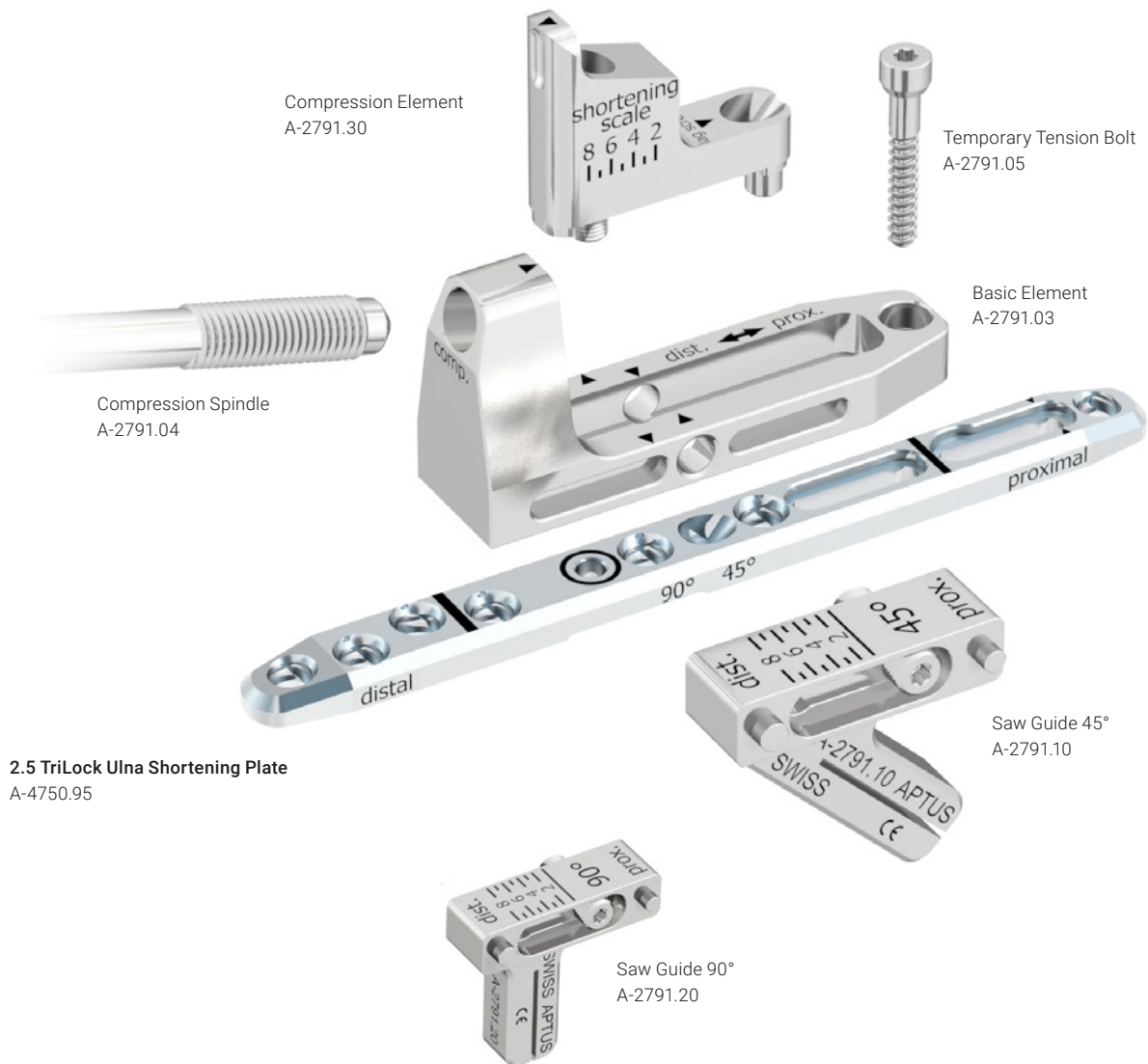

Instrument Application

General Instrument Application

Drilling

Color-coded twist drills are available for every APTUS system size. All twist drills are color coded with a ring system.

System Size	Color Code
2.5	Purple

There are two different types of twist drills for the system size 2.5: The core hole drills are characterized by one colored ring, the gliding hole drills (for lag screw technique) are characterized by two colored rings.

Warning

The twist drill must always be guided by a drill guide. This prevents damage to the plate hole and protects the surrounding tissue from direct contact with the drill. The drill guide also serves to limit the pivoting angle.

After positioning the plate, insert the drill guide and the twist drill into the plate hole.

Notice

The double-ended drill guide for lag screws (A-2721) is used only to perform the classic lag screw technique according to AO/ASIF.

Warning

For TriLock plates ensure that the screw holes are predrilled with a pivoting angle of no more than $\pm 15^\circ$. For this purpose, the drill guides feature a limit stop of $\pm 15^\circ$. A predrilled pivoting angle of $>15^\circ$ no longer allows the TriLock screws to correctly lock in the plate.

Warning

Twist drills and reamers: It is recommended not to exceed a maximum drilling speed of 1'000 revolutions per minute to avoid overheating the bone. The drill guide and bone should be cooled while drilling.



Core Hole Drills = one colored ring



Gliding Hole Drills = two colored rings



A-2791.06
2.5 Drill Guide for Ulna Shortening



A-2721
2.5 Drill Guide for Lag Screws

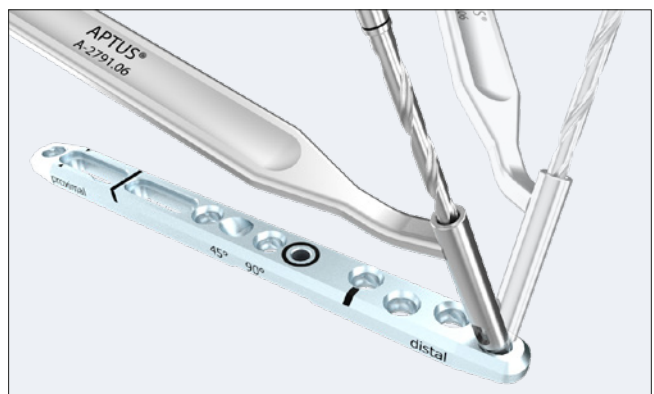

Assigning the Screw Length

The depth gauge (A-2730) is used to assign the ideal screw length for use in monocortical or bicortical screw fixation of TriLock screws and cortical screws.



A-2730
2.5 Depth Gauge

Retract the slider of the depth gauge.

The depth gauge caliper has a hooked tip that is either inserted to the bottom of the hole or is used to catch the far cortex of the bone. When using the depth gauge, the caliper stays static, only the slider is adjusted.



To assign the screw length, place the distal end of the slider onto the implant plate or directly onto the bone (e.g. for fracture fixation with lag screws).



The ideal screw length for the assigned drill hole can be read on the scale of the depth gauge.

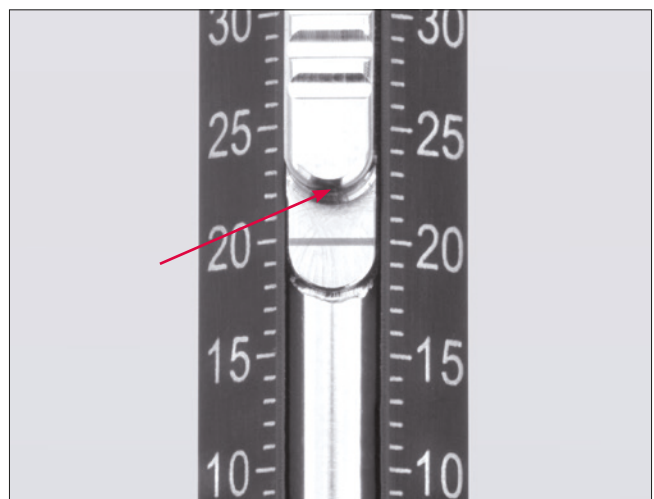

Screw Pick-Up

The screwdriver (A-2710) and the screwdriver blade (A-2013) feature the patented HexaDrive self-holding system.



A-2710
2.5 Screwdriver, Self-Holding, HD7



A-2013
2.5/2.8 Screwdriver Blade, HD7, AO



A-2073
Handle with Quick Connector, AO

To remove the screws from the implant container, insert the appropriately color-coded screwdriver perpendicularly into the screw head of the desired screw and pick up the screw with axial pressure.

Notice

The screw will not hold without axial pressure!

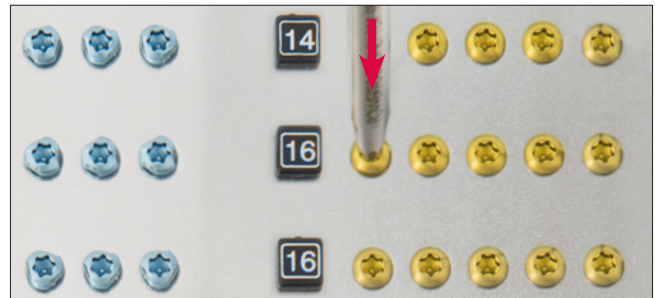

Vertically extract the screw from the compartment.

Notice

Picking up the screw repeatedly may lead to permanent deformation of the self-retaining area of the HexaDrive inside the screw head. Therefore, the screw may no longer be able to be picked up correctly. In this case, a new screw has to be used.

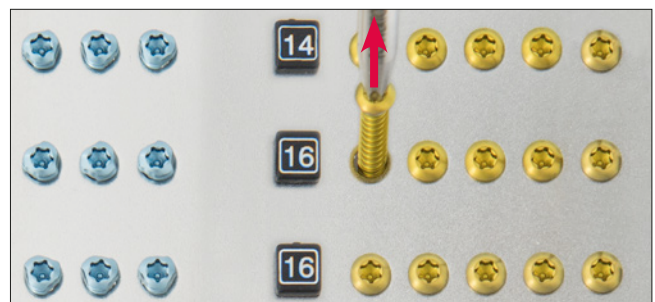

Check the screw length and diameter at the scale of the measuring module. The screw length is determined at the end of the screw head.

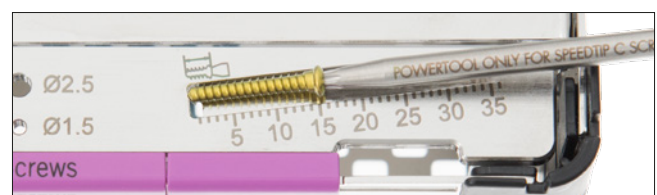

Surgical Techniques

General Surgical Techniques

Lag Screw Technique

1. Drilling the gliding hole

Drill the gliding hole (Ø 2.6 mm) using the twist drill marked with two purple rings in combination with the end of the drill guide (A-2721) labeled with two purple bars. Drill perpendicular to the fracture line.

Notice

Do not drill further than to the fracture line.



2. Drilling the core hole

Insert the other end of the drill guide (A-2721) into the drilled gliding hole and use the twist drill for core holes with one purple ring (A-3713, A-3723, A-3733, Ø 2.0 mm) to drill the core hole.



3. Compressing the fracture

Compress the fracture with the corresponding cortical screw (A-5700.xx).

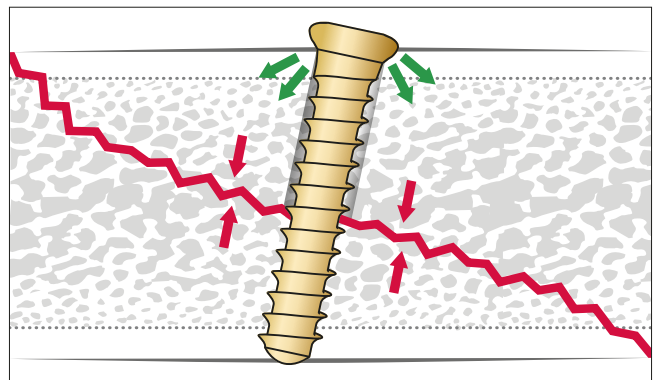

Specific Surgical Techniques

Ulna Shortening with Saw Guide 45°

Insert the compression element (A-2791.30) into the basic element (A-2791.03) and fix it to the plate with the help of the integrated screw. To tighten the screw, use the screwdriver blade (A-2013) with the handle (A-2073).

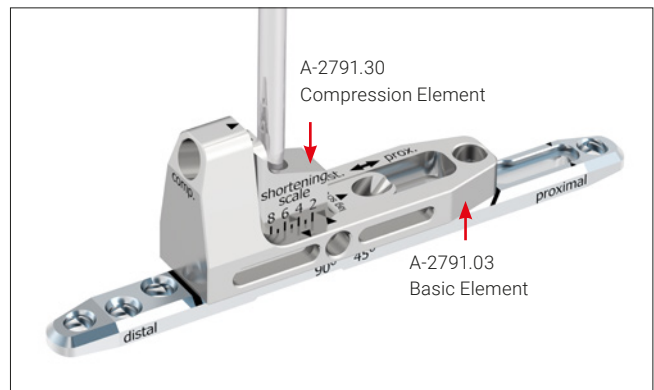

Notice

The correct position of the basic element (A-2791.03) is indicated by two laser markings on the plate (A-4750.95).

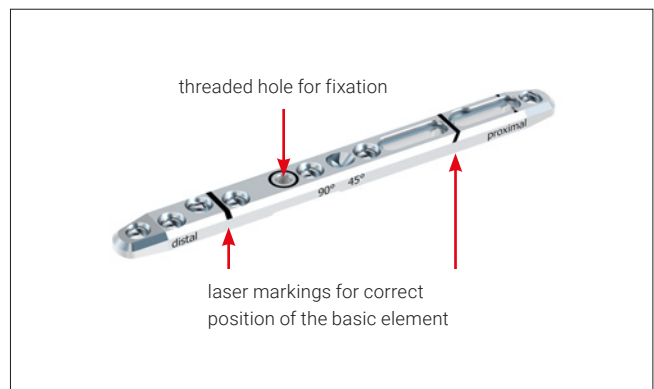

Mounting of the saw guide 45° (A-2791.10) on the basic element (A-2791.03). Fix the saw guide 45° **at the starting position** using the integrated screw. Tighten the screw using the screwdriver blade (A-2013) with the handle (A-2073).

Notice

The saw guide 45° can be mounted on either side of the basic element.

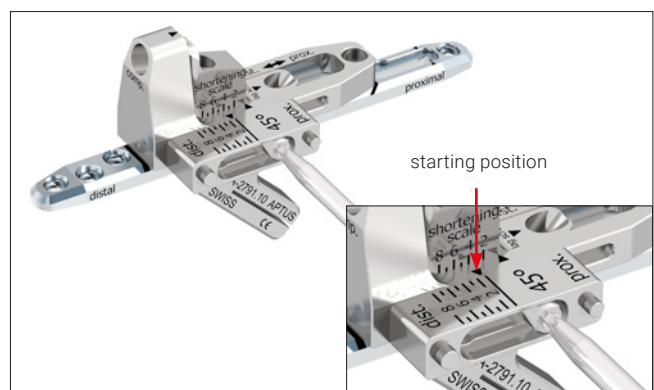

Drill a core hole through the most distal plate hole using the corresponding side of the drill guide (A-2791.06) and the APTUS twist drill (A-3713, A-3723 or A-3733) for core diameter 2.0 mm (one purple ring).

Initially, a gold cortical screw \varnothing 2.5 mm (A-5700.xx) can be inserted to achieve a contact between plate and bone or, alternatively, a blue TriLock screw (A-5750.xx) can be used.

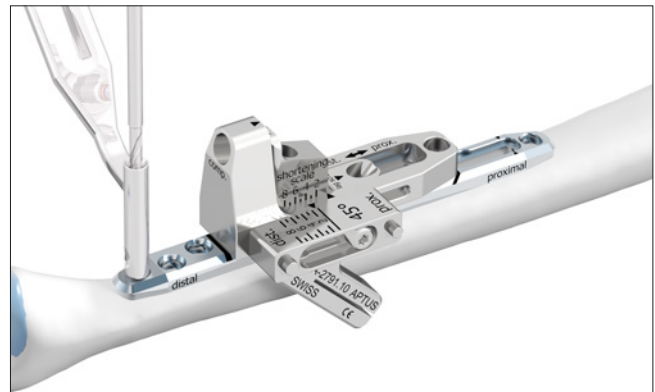

Drill a core hole through the proximal end of the oblong hole using the corresponding side of the drill guide (A-2791.06) and the APTUS twist drill (A-3713, A-3723 or A-3733) for core diameter 2.0 mm (one purple ring). Insert a gold cortical screw \varnothing 2.5 mm.

Warning

Do not insert blue TriLock screws \varnothing 2.5 mm into the oblong hole.

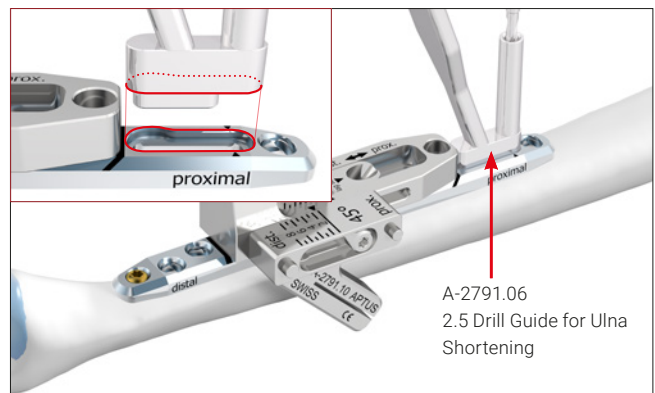

A-2791.06
2.5 Drill Guide for Ulna Shortening

Insert two blue TriLock screws \varnothing 2.5 mm into the distal plate holes.

Drill a core hole through the proximal end of the basic element (A-2791.03) using the corresponding side of the drill guide (A-2791.06) and the APTUS twist drill (A-3713, A-3723 or A-3733) for core diameter 2.0 mm (one purple ring).

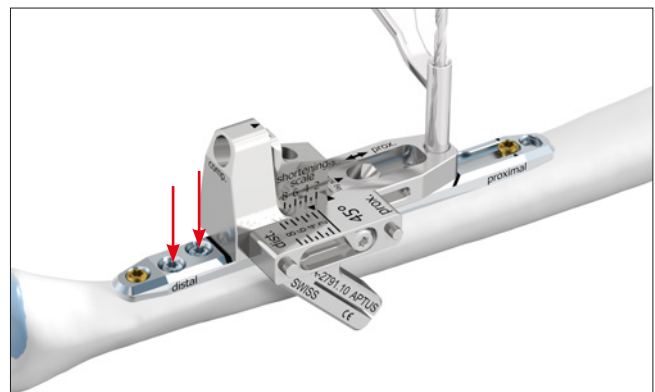

Insert the temporary tension bolt (A-2791.05). The temporary tension bolt is required for force transmission during the compression.

Caution

The temporary tension bolt is for **single use** only and has to be discarded after each use.

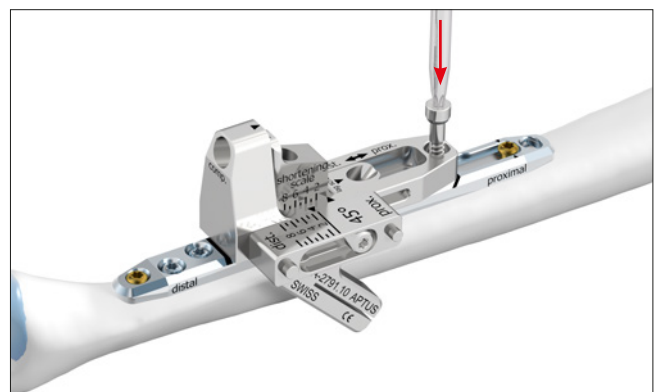

Start the osteotomy at the starting position and make the first cut.

Caution

To ensure a precise osteotomy, the saw blade must have the following dimensions:

Thickness: 0.40 mm Width: ~10 mm Cutting length: ~30 mm

Caution

Make sure that the plate does not get damaged during sawing.

Slight loosening of the screw integrated in the saw guide 45° allows to re-position the saw guide according to the amount of shortening preferred. Fix the saw guide at this new position by retightening the screw.

Perform the second cut.

Remove the saw guide 45° and the bone wafer.

Warning

Make sure that the bone wafer is completely removed and no bone debris remains in the osteotomy gap, which might prevent complete closure of the gap.

Slightly loosen the proximal cortical screw in the oblong hole of the plate and the temporary tension bolt (A-2791.05) in the basic element (½ - max ¾ turn).

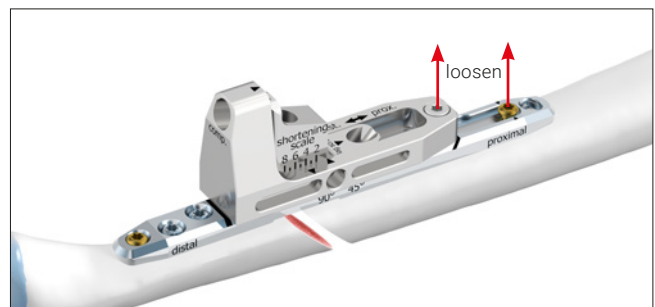
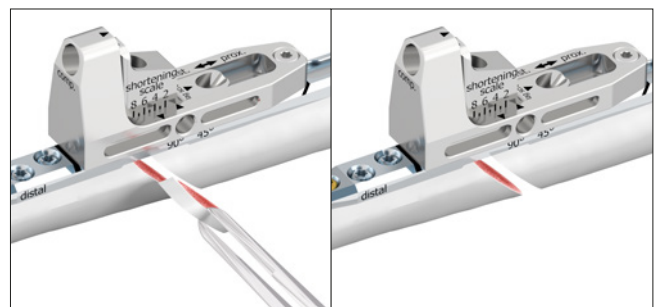
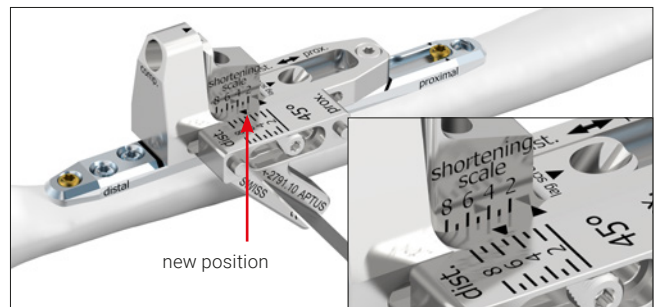
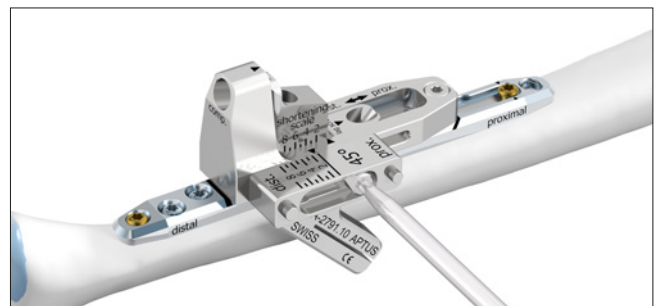
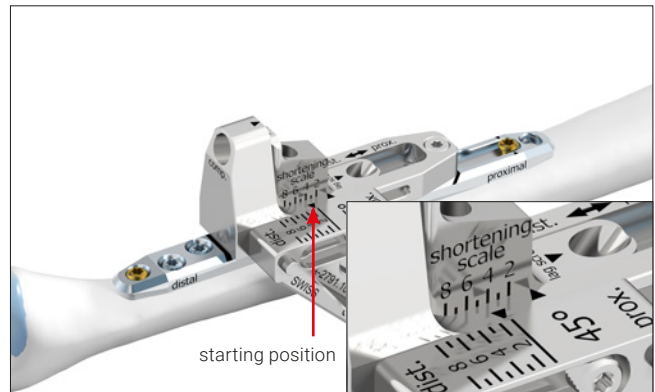

Manually insert the compression spindle (A-2791.04, Quick Connector AO) into the basic element. Use the connected handle (A-2073) to close the osteotomy until the adequate compression is achieved.

Warning

The compression spindle must be lubricated immediately before inserting it into the basic element, refer to Instructions for Use for Medartis APTUS Plates, Screws and Instruments (chapter "Product Care").

Warning

Double-check the shortening length on the "shortening scale" to avoid over-compression.

Retighten the gold cortical screw \varnothing 2.5 mm in the most proximal oblong hole.

Drill a 45° core hole using the drill guide (A-2791.06) and the APTUS twist drill (A-3713, A-3723 or A-3733) for core diameter 2.0 mm (one purple ring).

Insert a gold cortical screw \varnothing 2.5 mm (set screw).

Notice

In case of inadequate closure of the osteotomy gap, utilize the lag screw technique (see chapter "Surgical Technique Lag Screw Technique").

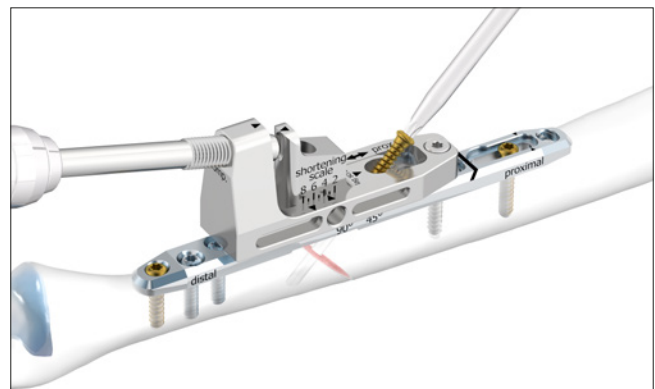
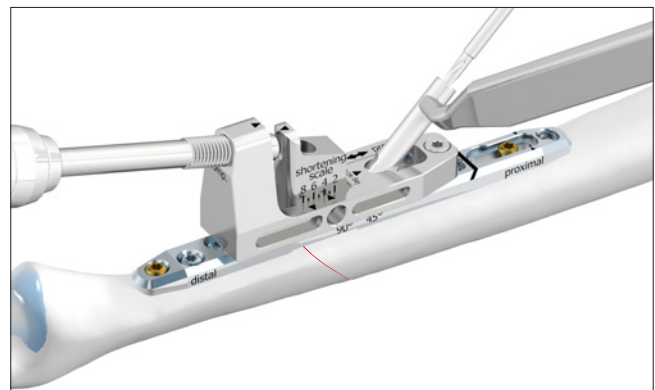
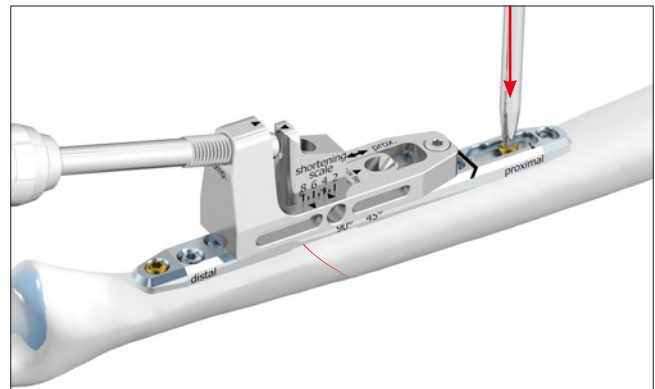
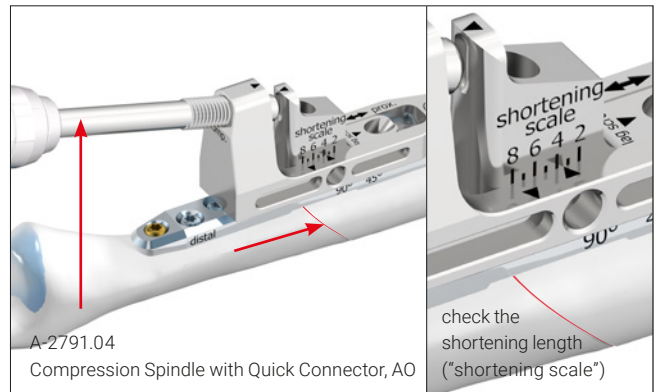

Insert a blue TriLock screw \varnothing 2.5 mm in the most proximal plate hole.

Remove the compression spindle (A-2791.04).

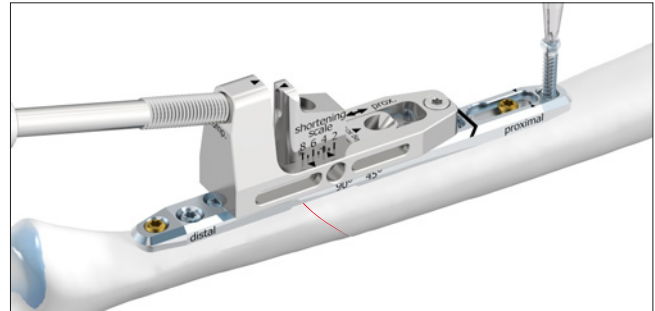

Remove the temporary tension bolt (A-2791.05) in the basic element (A-2791.03).

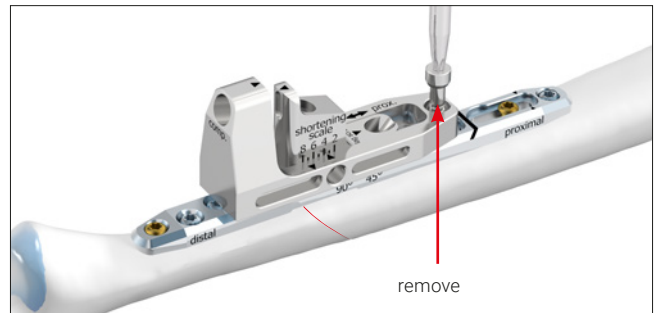

Loosen the screw integrated in the compression element (A-2791.30). Remove the basic element (A-2791.03) and the compression element (A-2791.30).

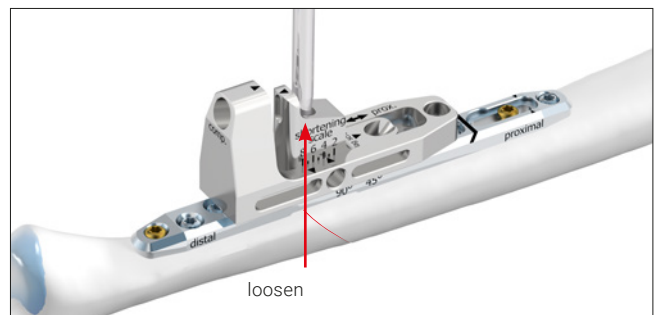

Complete the fixation of the plate. Insert two blue TriLock screws \varnothing 2.5 mm into two locking holes and one gold cortical screw \varnothing 2.5 mm into the distal oblong hole.

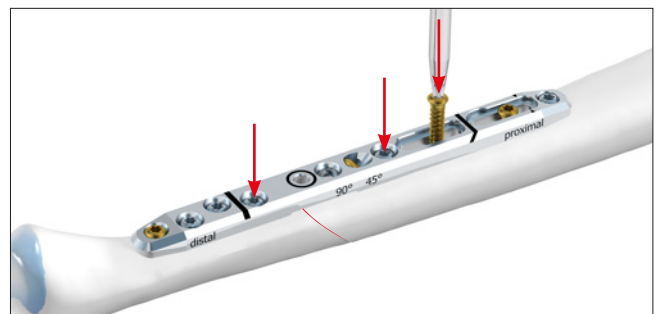

Warning

Do not insert screws into the hole marked with a black ring. Also, only with the 45° technique, do not insert a screw into the hole proximal to it, as this causes a collision with the set screw.

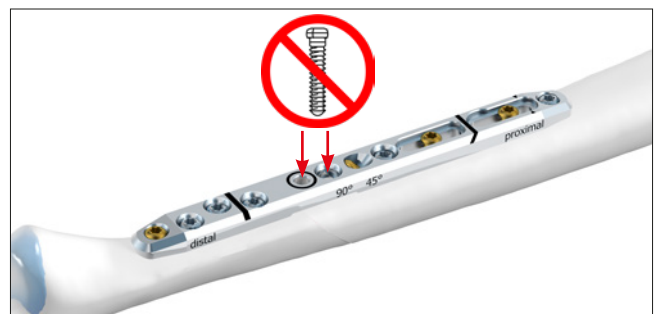

Ulna Shortening with Saw Guide 90°

Insert the compression element (A-2791.30) into the basic element (A-2791.03) and fix it to the plate with the help of the integrated screw. To tighten the screw, use the screwdriver blade (A-2013) with the handle (A-2073).

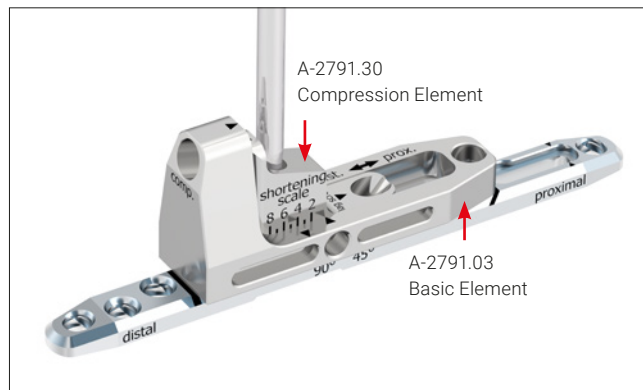

Notice

The correct position of the basic element (A-2791.03) is indicated by two laser markings on the plate (A-4750.95).

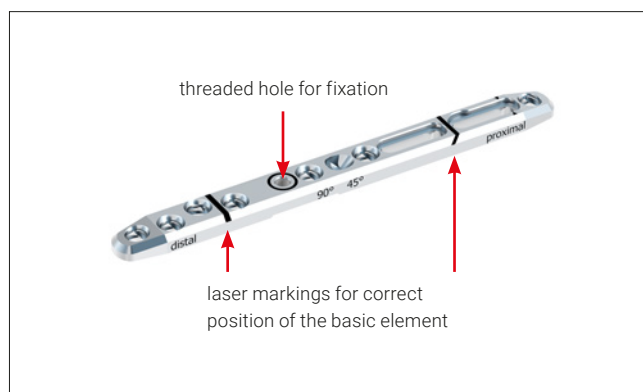

Mounting of the saw guide 90° (A-2791.20) on the basic element (A-2791.03). Fix the saw guide 90° **at the starting position** using the integrated screw. Tighten the screw using the screwdriver blade (A-2013) with the handle (A-2073).

Notice

The saw guide 90° can be mounted on either side of the basic element.

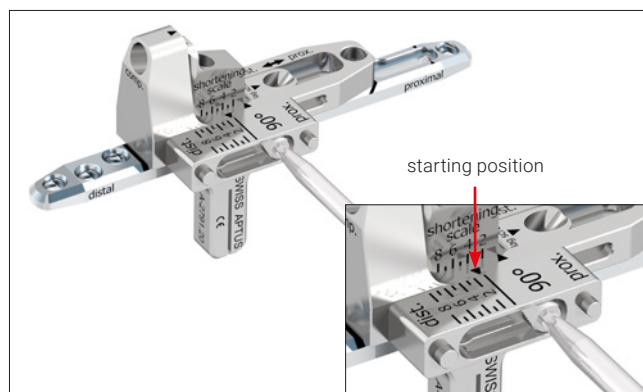

Drill a core hole through the most distal plate hole using the corresponding side of the drill guide (A-2791.06) and the APTUS twist drill (A-3713, A-3723 or A-3733) for core diameter 2.0 mm (one purple ring).

Initially, a gold cortical screw \varnothing 2.5 mm (A-5700.xx) can be inserted to achieve a contact between plate and bone or, alternatively, a blue TriLock screw (A-5750.xx) can be used.

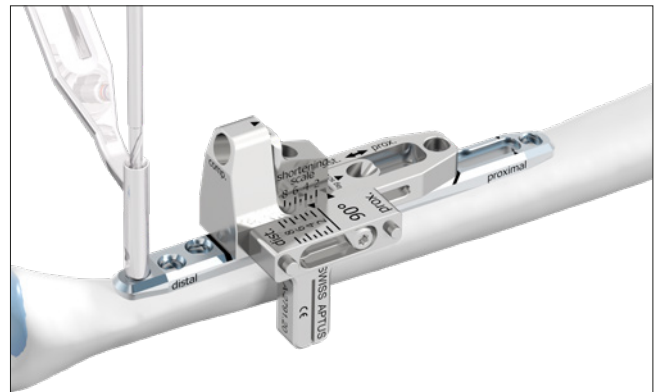

Drill a core hole through the proximal end of the oblong hole using the corresponding side of the drill guide (A-2791.06) and the APTUS twist drill (A-3713, A-3723 or A-3733) for core diameter 2.0 mm (one purple ring). Insert a gold cortical screw \varnothing 2.5 mm.

Warning

Do not insert blue TriLock screws \varnothing 2.5 mm into the oblong hole.

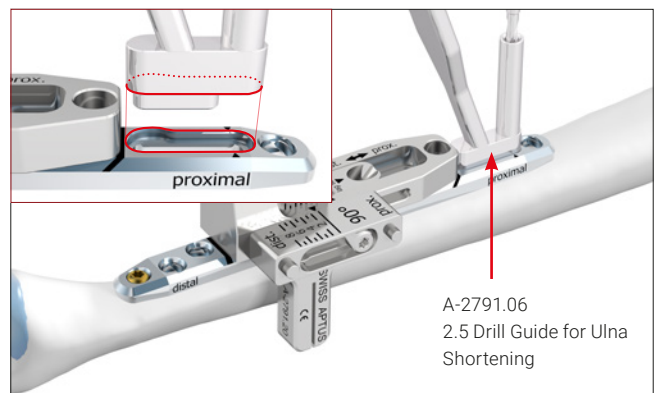

Insert two blue TriLock screws \varnothing 2.5 mm into the distal plate holes.

Drill a core hole through the proximal end of the basic element (A-2791.03) using the corresponding side of the drill guide (A-2791.06) and the APTUS twist drill (A-3713, A-3723 or A-3733) for core diameter 2.0 mm (one purple ring).

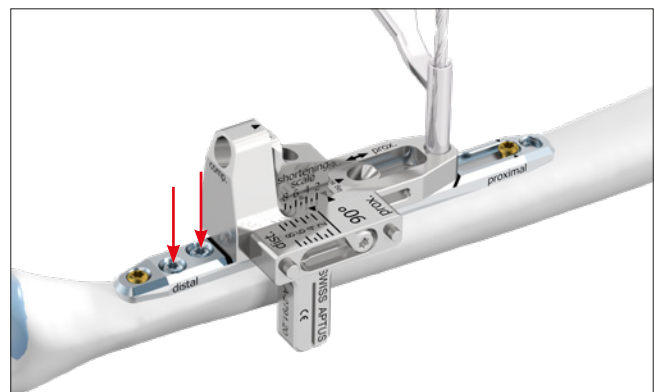

Insert the temporary tension bolt (A-2791.05). The temporary tension bolt is required for force transmission during the compression.

Caution

The temporary tension bolt is for **single use** only and has to be discarded after each use.

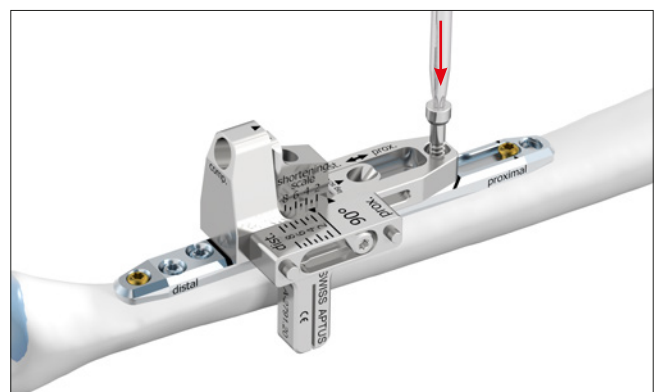

Start the osteotomy at the starting position and make the first cut.

Caution

To ensure a precise osteotomy, the saw blade must have the following dimensions:

- Thickness: 0.40 mm
- Width: ~10 mm
- Cutting length: ~30 mm

Caution

Make sure that the plate does not get damaged during sawing.

Slight loosening of the screw integrated in the saw guide 90° allows to re-position the saw guide according to the amount of shortening preferred. Fix the saw guide at this new position by retightening the screw.

Perform the second cut.

Remove the saw guide 90° and the bone wafer.

Warning

Make sure that the bone wafer is completely removed and no bone debris remains in the osteotomy gap, which might prevent complete closure of the gap.

Slightly loosen the proximal cortical screw in the oblong hole of the plate and the temporary tension bolt (A-2791.05) in the basic element (½ – max ¾ turn).

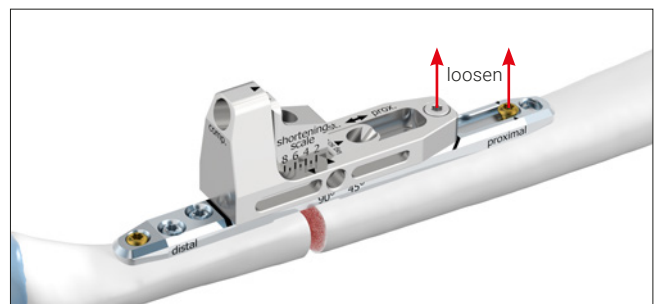
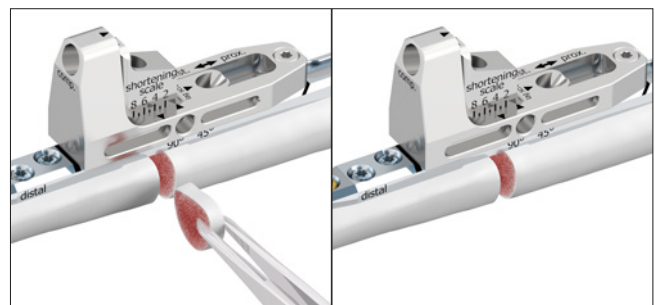
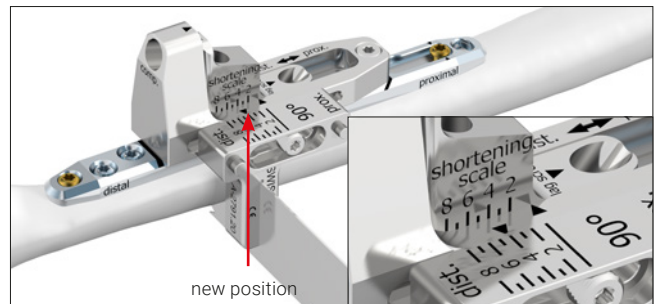
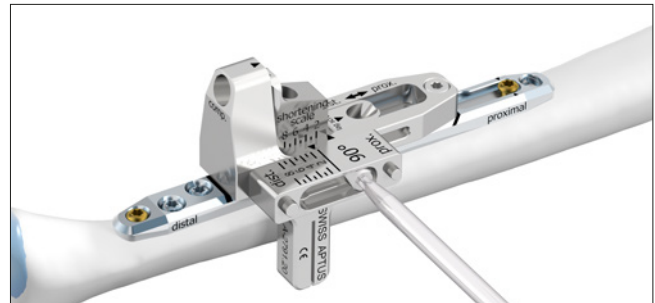
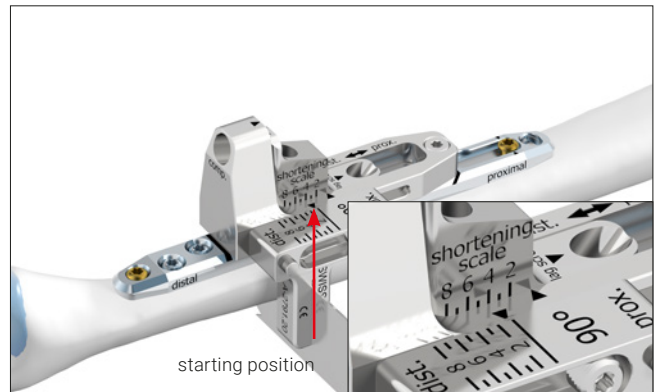

Manually insert the compression spindle (A-2791.04, Quick Connector AO) into the basic element. Use the connected handle (A-2073) to close the osteotomy until the adequate compression is achieved.

Warning

The compression spindle must be lubricated immediately before inserting it into the basic element, refer to "Instructions for Use for Medartis APTUS Plates, Screws and Instruments" (section "Product Care").

Warning

Double-check the shortening length on the "shortening scale" to avoid over-compression.

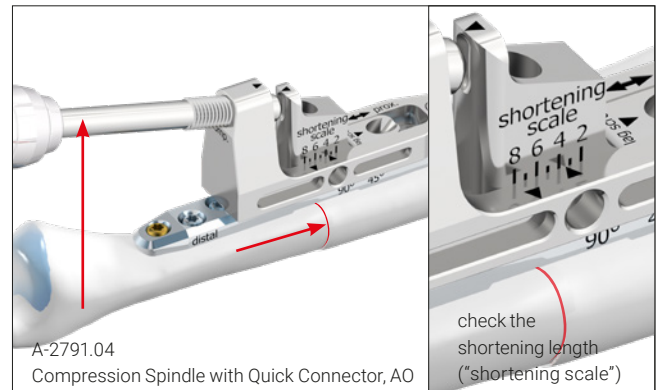

Retighten the gold cortical screw Ø 2.5 mm in the oblong hole of the plate.

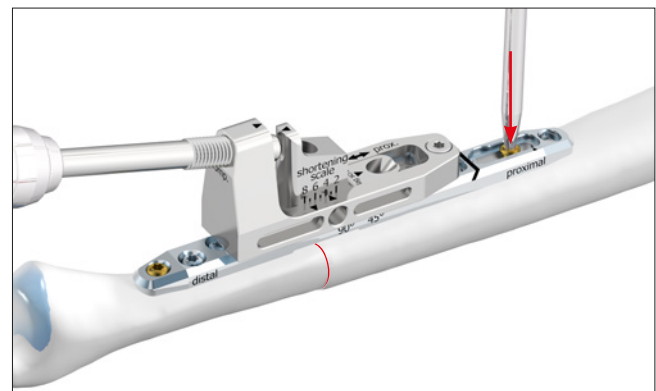

Insert a blue TriLock screw Ø 2.5 mm in the most proximal plate hole.

Remove the compression spindle (A-2791.04).

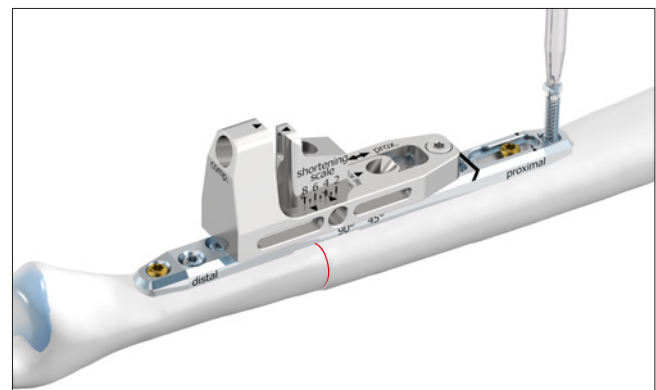

Remove the temporary tension bolt (A-2791.05) in the basic element (A-2791.03).

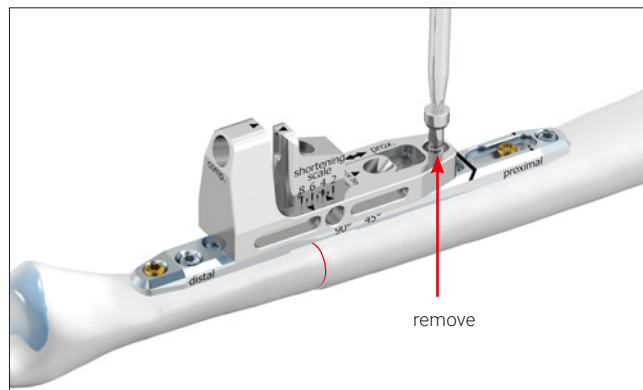

Loosen the screw integrated in the compression element (A-2791.30).
Remove the basic element (A-2791.03) and the compression element (A-2791.30).

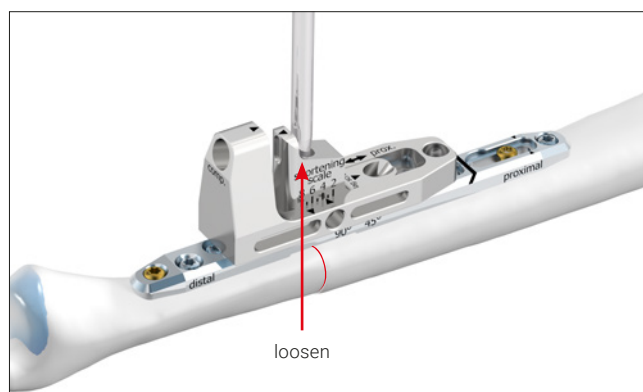

Complete the fixation of the plate. Insert three blue TriLock screws \varnothing 2.5 mm into the remaining locking holes and one gold cortical screw \varnothing 2.5 mm into the distal oblong hole.

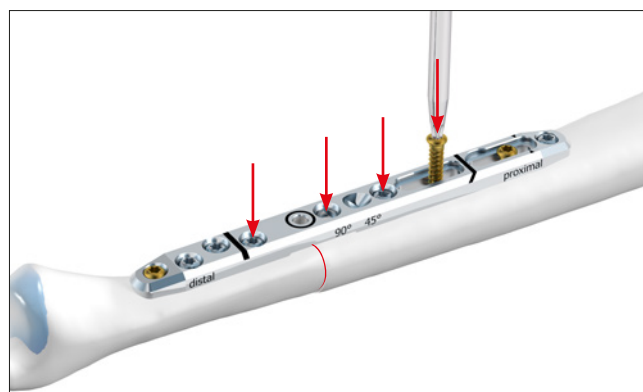

Warning

Do not insert screws into the hole marked with a black ring. Also, only with the 90° technique, do not insert a screw into the second hole proximal to it, as this causes a collision.

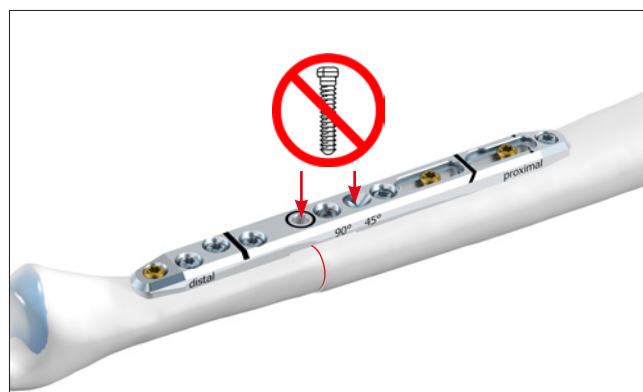

Explantation

Explantation of Ulna Shortening Plates

1. Removing the screws

Unlock all screws and remove them.

The order in which the screws are removed is not relevant.

In case the plate sticks to the bone, use a periosteal elevator to carefully lift and detach it from the bone.

Notice

When removing the screws, make sure that the screwdriver/screw head connection is aligned in axial direction.

TriLock Locking Technology

Correct Application of the TriLock Locking Technology

The screw is inserted through the plate hole into a predrilled canal in the bone. An increase of the tightening torque will be felt as soon as the screw head gets in contact with the plate surface.

This indicates the start of the "Insertion Phase" as the screw head starts entering the locking zone of the plate (section "A" in the diagram). Afterwards, a drop of the tightening torque

occurs (section "B" in the diagram). Finally the actual locking is initiated (section "C" in the diagram) as a friction connection is established between screw and plate when tightening firmly.

The torque applied during fastening of the screw is decisive for the quality of the locking as described in section "C" of the diagram.

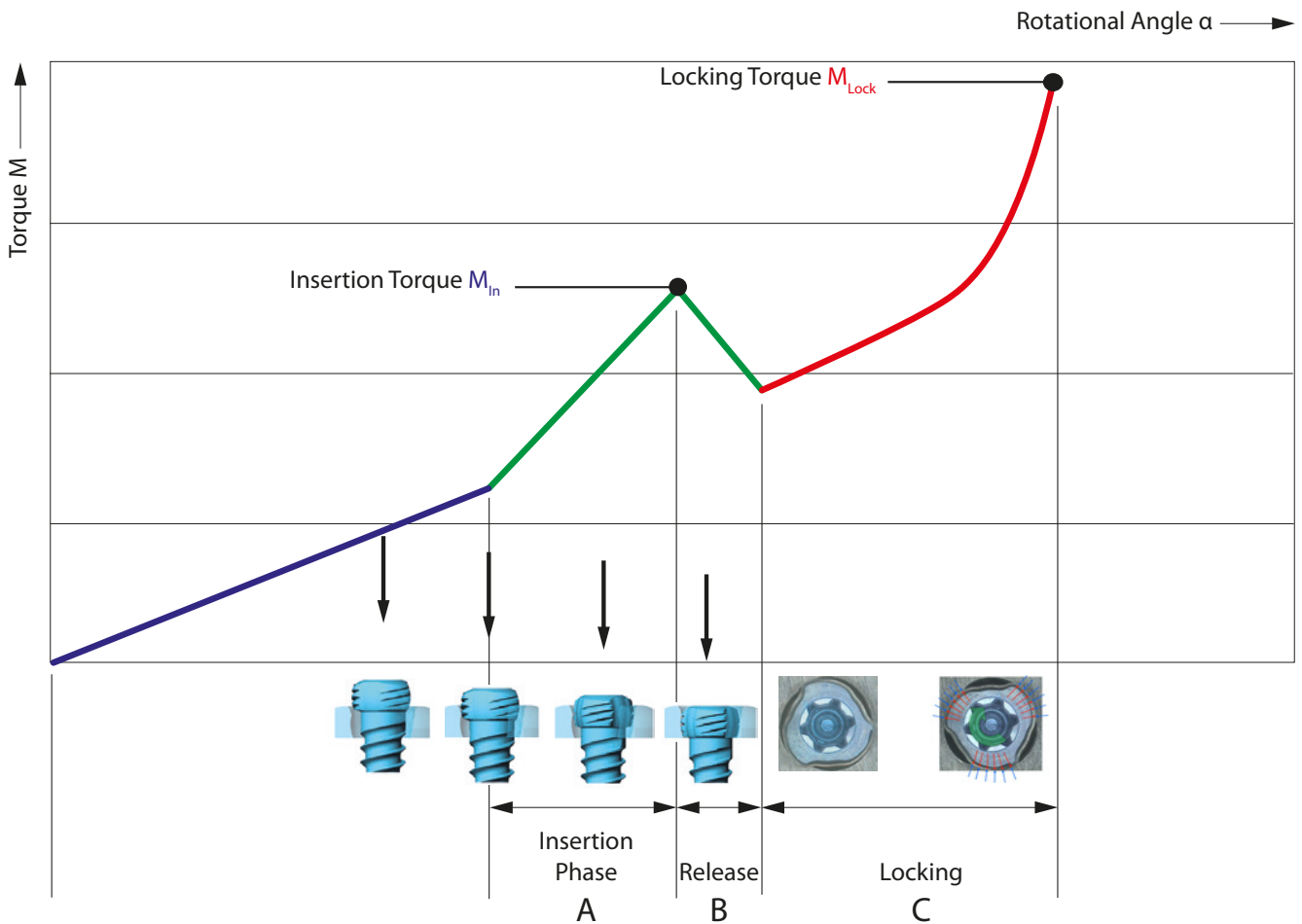

Correct Locking ($\pm 15^\circ$) of the TriLock Screws in the Plate

Correct locking occurs only when the screw head is locked flush with the locking contour (Fig. 1 and 3).

However, if there is still a noticeable protrusion (Fig. 2 and 4), the screw head has not completely reached the locking position. In this case, the screw has to be retightened to obtain full penetration and proper locking. In case of poor

bone quality a slight axial pressure may be necessary to achieve proper locking. Due to the system characteristics, a screw head protrusion of around 0.2 mm exists when using plates with 1.0 mm thickness.

After having reached the locking torque (M_{Lock}), do not further tighten the screw, otherwise the locking function cannot be guaranteed anymore.

Correct: LOCKED

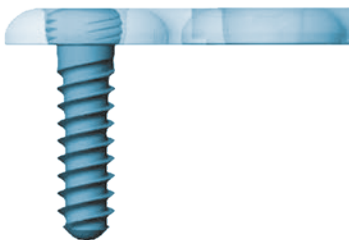

Figure 1

Incorrect: UNLOCKED

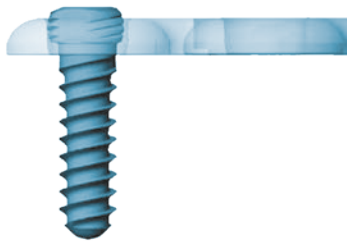

Figure 2

Correct: LOCKED

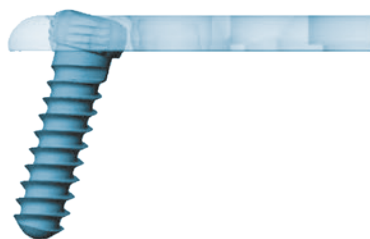

Figure 3

Incorrect: UNLOCKED

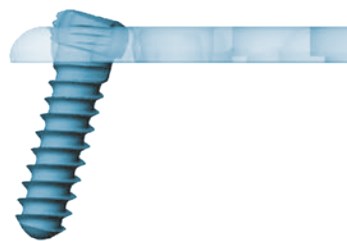
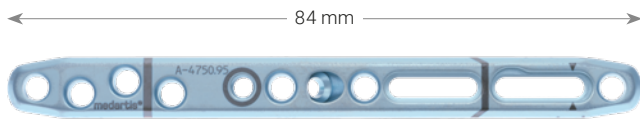

Figure 4

Implants, Instruments and Containers

2.5 TriLock Ulna Shortening Plate

Material: Titanium (ASTM F67)
Plate thickness: 3.2 mm



Art. No.	STERILE	Holes	Pieces / Pkg
A-4750.95	A-4750.95S	10	1

Basic Element



Art. No.	Pieces / Pkg
A-2791.03	1

Saw Guides (incl. Screw)



A-2791.10

A-2791.20

Art. No.	Description	Pieces / Pkg
A-2791.10	45° (incl. screw)	1
A-2791.20	90° (incl. screw)	1
A-2791.01	screw for saw guide	1

Compression Element (incl. Screw)



Art. No.	Description	Pieces / Pkg
A-2791.30	incl. screw	1
A-2791.02	screw for compression element	1

Compression Spindle with Quick Connector



Art. No.	Shaft End	Pieces / Pkg
A-2791.04	A0	1

Temporary Tension Bolt



Art. No.	Description	Pieces / Pkg
A-2791.05	for single use	1

Saw Blades * **STERILE**



KM3.125 STE



KM3101 STE



KM519.013 STE

Art. No.	Connections for	Cutting Depth	Cutting Width	Material Thickness	Pieces / Pkg
KM3.125 STE	Stryker, NSK	31.00 mm	9.80 mm	0.40 mm	5
KM3101 STE	ConMed, Linvatec Hall, MicroAire, S&N Dyonics	25.50 mm	10.00 mm	0.40 mm	5
KM519.013 STE	Synthes, Zimmer UPS	25.00 mm	9.50 mm	0.40 mm	5

* Saw blades are available for the following countries: Austria, Belgium, Croatia, Czech Republic, Denmark, France, Germany, Greece, Hungary, Ireland, Italy, Latvia, Lithuania, Luxembourg, Netherlands, Norway, Poland, Portugal, Slovakia, Slovenia, Spain, Sweden, Switzerland, UK, USA

2.5 Cortical Screws, HexaDrive 7

Material: Titanium alloy (ASTM F136)



Ø 2.5 mm

Length	Art. No.	STERILE	Pieces / Pkg	Art. No.	Pieces / Pkg
8 mm	A-5700.08/1	A-5700.08/1S	1	A-5700.08	5
10 mm	A-5700.10/1	A-5700.10/1S	1	A-5700.10	5
12 mm	A-5700.12/1	A-5700.12/1S	1	A-5700.12	5
14 mm	A-5700.14/1	A-5700.14/1S	1	A-5700.14	5
16 mm	A-5700.16/1	A-5700.16/1S	1	A-5700.16	5
18 mm	A-5700.18/1	A-5700.18/1S	1	A-5700.18	5
20 mm	A-5700.20/1	A-5700.20/1S	1	A-5700.20	5
22 mm	A-5700.22/1	A-5700.22/1S	1	A-5700.22	5
24 mm	A-5700.24/1	A-5700.24/1S	1	A-5700.24	5
26 mm	A-5700.26/1	A-5700.26/1S	1	A-5700.26	5

2.5 TriLock Screws, HexaDrive 7

Material: Titanium alloy (ASTM F136)

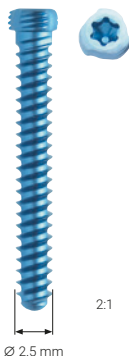

Ø 2.5 mm

Length	Art. No.	STERILE	Pieces / Pkg	Art. No.	Pieces / Pkg
8 mm	A-5750.08/1	A-5750.08/1S	1	A-5750.08	5
10 mm	A-5750.10/1	A-5750.10/1S	1	A-5750.10	5
12 mm	A-5750.12/1	A-5750.12/1S	1	A-5750.12	5
14 mm	A-5750.14/1	A-5750.14/1S	1	A-5750.14	5
16 mm	A-5750.16/1	A-5750.16/1S	1	A-5750.16	5
18 mm	A-5750.18/1	A-5750.18/1S	1	A-5750.18	5
20 mm	A-5750.20/1	A-5750.20/1S	1	A-5750.20	5
22 mm	A-5750.22/1	A-5750.22/1S	1	A-5750.22	5
24 mm	A-5750.24/1	A-5750.24/1S	1	A-5750.24	5

Twist Drills Ø 2.0 mm



Art. No.	STERILE	System Size	Stop	Length	Shaft End	Pieces / Pkg
A-3713	A-3713S	2.5	40 mm	97 mm	Dental	1
A-3723	A-3723S	2.5	40 mm	97 mm	Stryker J-Latch	1
A-3733	A-3733S	2.5	40 mm	91 mm	AO Quick Coupling	1

Twist Drill Ø 2.6 mm (for Gliding Hole)



Art. No.	STERILE	System Size	Stop	Length	Shaft End	Pieces / Pkg
A-3731	A-3731S	2.5	10 mm	61 mm	AO Quick Coupling	1

Drill Guides



Art. No.	System Size	Description	Length	Pieces / Pkg
A-2791.06	2.5	for ulna shortening	144 mm	1
A-2721	2.5	for lag screws	144 mm	1

Depth Gauge



Art. No.	System Size	Description	Length	Pieces / Pkg
A-2730	2.5		151 mm	1
A-2730.1	2.5	caliper	149 mm	1

Handle with Quick Connector



Art. No.	Description	Length	for Shaft End	Pieces / Pkg
A-2073	with twist cap	124 mm	AO Quick Coupling	1

Screwdriver Blade, Self-Holding



Art. No.	System Size	Description	Length	Shaft End	Pieces / Pkg
A-2013	2.5 / 2.8	HD7	75 mm	AO Quick Coupling	1

Cases, Trays

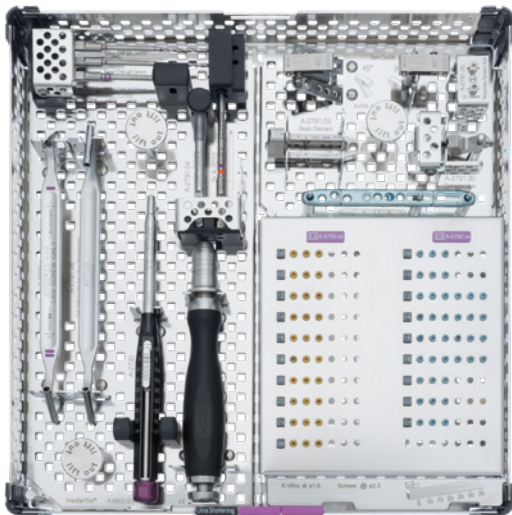

A-6602.049 with A-6602.005 + A-6602.007
(excl. implants and instruments)



A-6602.011 with A-6602.006
(excl. implants and instruments)

Art. No.	Description	Dimension (W x L)	Pieces / Pkg
A-6602.005	implant/instrument tray APTUS Ulna Shortening	93 x 118 mm	1
A-6602.006	implant/instrument tray APTUS Ulna Shortening	114 x 234 mm	1
A-6602.007	instrument tray for APTUS Ulna Shortening	114 x 234 mm	1
A-6602.011	implant/instrument case APTUS Ulna Shortening	120 x 240 mm	1
A-6602.049	case APTUS Ulna Shortening	240 x 240 mm	1
M-6706	lid for implant and instrument case	120 x 240 mm	1
M-6707	lid for implant and instrument case	240 x 240 mm	1

R_WRIST-10010001_v0 / © 2021-03, Medartis AG, Switzerland. All technical data subject to alteration.

MANUFACTURER & HEADQUARTERS

Medartis AG | Hochbergerstrasse 60E | 4057 Basel / Switzerland
P +41 61 633 34 34 | F +41 61 633 34 00 | www.medartis.com

SUBSIDIARIES

Australia | Austria | Brazil | China | France | Germany | Japan | Mexico | New Zealand | Poland | Spain | UK | USA

For detailed information regarding our subsidiaries and distributors, please visit www.medartis.com



Disclaimer: This information is intended to demonstrate the Medartis portfolio of medical devices. A surgeon must always rely on her or his own professional clinical judgement when deciding whether to use a particular product when treating a particular patient. Medartis is not giving any medical advice. The devices may not be available in all countries due to registration and / or medical practices. For further questions, please contact your Medartis representative (www.medartis.com). This information contains CE-marked products.
For US only: Federal law restricts this device to sale by or on the order of a physician.