

medartis

PRECISION IN FIXATION

SURGICAL TECHNIQUE

MODUS 2 Mandible



MODUS

Contents

3	Introduction
3	Product Materials
3	Indications
3	Contraindications
3	Color Coding
4	Possible Combination of Plates and Screws
4	Symbols
5	System Overview
7	Treatment Concept
7	Condyle Fractures
8	Body Fractures
9	Ramus and Angle Fractures
10	Atrophic Mandible Fractures
11	HCL Defect Classification
12	Reconstruction
13	Bridging of a Bone Defect
14	Instrument Application
14	General Instrument Application
14	Picking up the Plates
15	Cutting the Plates
18	Bending the Plates
22	Drilling
23	Drilling with Drill Guide
24	Assigning the Screw Length
25	Screw Pick-Up
27	Specific Instrument Application
27	Bending of TriLock Bridging Plates
33	Surgical Techniques
33	General Surgical Techniques
33	Lag Screw Technique
34	Specific Surgical Techniques
34	Assembly of the C-Adaption for Bridging Plates
36	Use of the Temporary Locking Stopper for TriLock Screws
38	Follow-Up Care and Explanation
38	Follow-Up Care for MODUS 2 Mandible Implants
38	Explanation of MODUS 2 Mandible Implants
39	TriLock Locking Technology
39	Correct Application of the TriLock Locking Technology
40	Correct Locking ($\pm 15^\circ$) of the TriLock Screws in the Plate
41	Implants, Instruments and Containers

For further information regarding the MODUS 2 product line, visit www.medartis.com.

Introduction

Product Materials

Plates	Pure titanium
Screws	Titanium alloy
Instruments	Stainless steel, PEEK, aluminum, Nitinol, silicone or titanium
Containers	Stainless steel, aluminum, PEEK, polyphenylsulfone, polyurethane, silicone

Indications

MODUS 2 Mandible is indicated for mandibular trauma repair, fixation of mandibular osteotomies, reconstructive procedures and bridging of load-bearing bone segments in the mandible.

Contraindications

- Preexisting or suspected infection at or near the implantation site
- Known allergies and/or hypersensitivity to implant materials
- Inferior or insufficient bone quality to securely anchor the implant
- Patients who are incapacitated and/or uncooperative during the treatment phase
- Blocking of growth plates with plates and screws

Color Coding

Screw Diameter

2.0
2.3
2.5

Color Code

Blue
Brown
Purple

Plates and Screws

Implant plates gold
Implant plates blue
Implant plates silver
Implant screws gold
Implant screws silver
Implant screws green

Rigid fixation plates
Semi-rigid fixation plates*
TriLock plates (locking)
Cortical screws (fixation)
TriLock screws (locking)
SpeedTip screws (self-drilling)
TriLock SpeedTip screws (locking and self-drilling)

* Semi-rigid is easier to form than rigid materials with the same plate geometry.

Possible Combination of Plates and Screws

Screws and plates can be combined as follows:

Plates	Screws
Fixation Plates	2.0 Cortical Screws, HexaDrive 6 2.0 SpeedTip Screws, HexaDrive 6 2.3 Cortical Screws, HexaDrive 6
TriLock Plates	2.0 TriLock Screws, HexaDrive 6 2.0 Cortical Screws, HexaDrive 6 2.0 TriLock SpeedTip Screws, HexaDrive 6 2.0 SpeedTip Screws, HexaDrive 6 2.3 TriLock Screws, HexaDrive 6 2.3 Cortical Screws, HexaDrive 6 2.5 TriLock Screws, HexaDrive 6

Caution

For bridging of bone defects, 2.5 TriLock screws have to be used in order to provide appropriate stability of the load-bearing screw-plate construct.

Symbols



HexaDrive



SpeedTip



System Overview

The implant plates of MODUS 2 Mandible are available in the following designs.

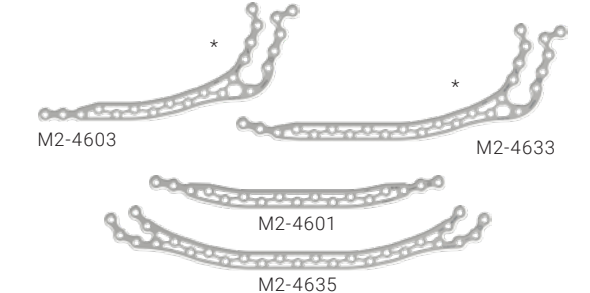
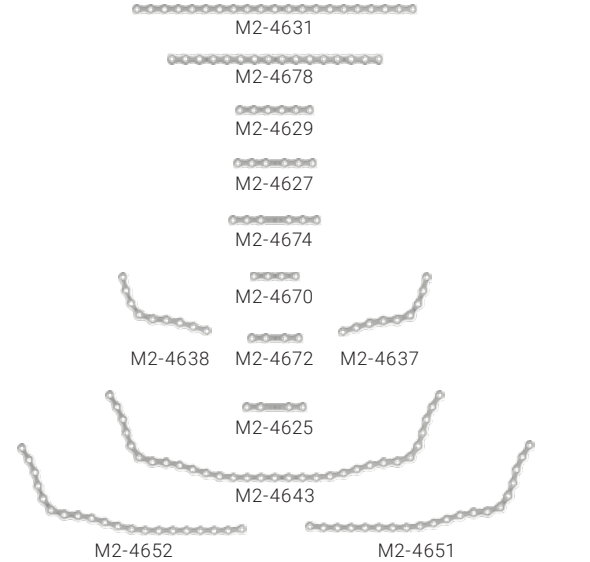
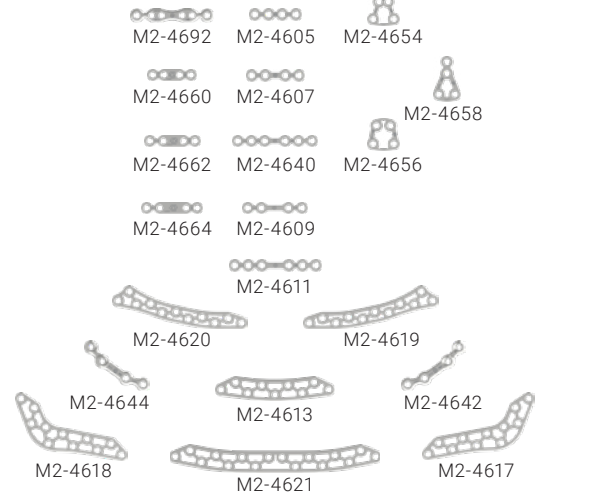
Description	Examples	Plate Thickness	Rigidity
TriLock Bridging Plates*		2.0 mm	
TriLock Plates		1.5 mm	Semi-Rigid
TriLock Plates		1.3 mm	

* TriLock bridging plates M2-4603 and M2-4633 have double-sided TriLock screw holes and can therefore be used for the left and right side.

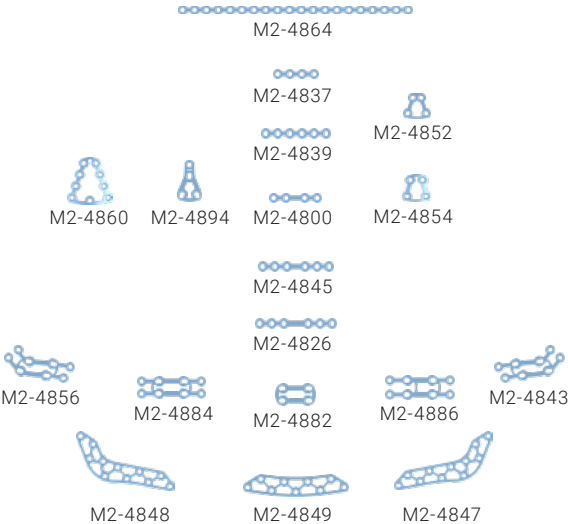
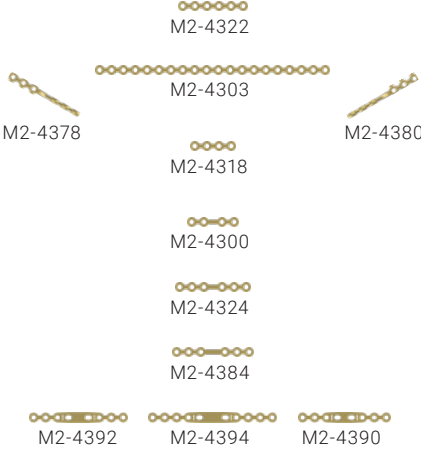
Description	Examples	Plate Thickness	Rigidity
<p>Fixation Plates</p>	 <p>M2-4864</p> <p>M2-4837</p> <p>M2-4839</p> <p>M2-4852</p> <p>M2-4860</p> <p>M2-4894</p> <p>M2-4800</p> <p>M2-4854</p> <p>M2-4845</p> <p>M2-4826</p> <p>M2-4856</p> <p>M2-4884</p> <p>M2-4882</p> <p>M2-4886</p> <p>M2-4843</p> <p>M2-4848</p> <p>M2-4849</p> <p>M2-4847</p>	<p>1.0 mm</p>	<p>Rigid</p>
	 <p>M2-4322</p> <p>M2-4303</p> <p>M2-4378</p> <p>M2-4380</p> <p>M2-4318</p> <p>M2-4300</p> <p>M2-4324</p> <p>M2-4384</p> <p>M2-4392</p> <p>M2-4394</p> <p>M2-4390</p>		

Treatment Concept

The table below lists typical clinical findings which can be treated with the implants of MODUS 2 Mandible.



Condyle Fractures

<p>TriLock Condyle Plate</p> <p>Plate thickness: 1.5 mm Semi-rigid</p>	 <p>M2-4692</p>			
<p>TriLock Condyle Plates</p> <p>Plate thickness: 1.3 mm Semi-rigid</p>	 <p>M2-4658</p>	 <p>M2-4654</p>	 <p>M2-4656</p>	 <p>M2-4660 M2-4662 M2-4664</p>
<p>Condyle Plates</p> <p>Plate thickness: 1.0 mm Semi-rigid</p>	 <p>M2-4894</p>	 <p>M2-4852</p>	 <p>M2-4854</p>	
<p>Mandible Plates, Straight</p> <p>Plate thickness: 1.0 mm Rigid</p>	 <p>M2-4300</p>			

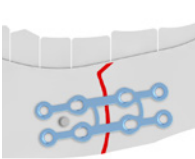
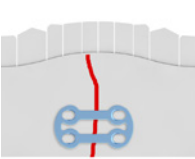
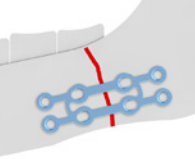
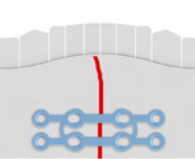
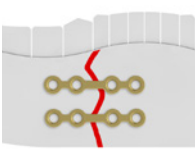

The information provided above is a recommendation only. The operating surgeon is solely responsible for choosing the appropriate implant for the specific case.

Body Fractures

Simple Fractures

<p>Grid Compression Plates</p> <p>Plate thickness: 1.0 mm Semi-rigid</p>	 <p>M2-4886</p>	 <p>M2-4882</p>	 <p>M2-4884</p>	 <p>M2-4884</p>	
<p>Mandible Plates, Straight</p> <p>Plate thickness: 1.0 mm Rigid</p>	 <p>M2-4300</p>	 <p>M2-4300 / M2-4384</p>			

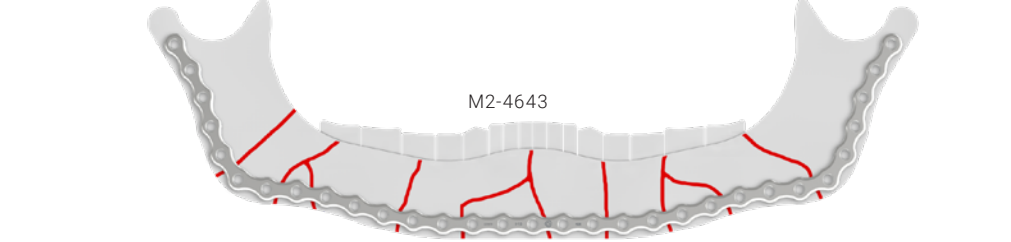
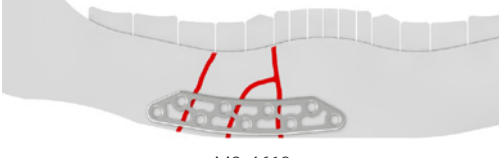
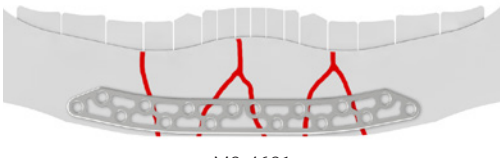
Comminuted Fractures

<p>TriLock Plates, Anatomical</p> <p>Plate thickness: 1.5 mm Semi-rigid</p>	 <p>M2-4643</p>	
<p>TriLock Median Paramedian Plates, Grid</p> <p>Plate thickness: 1.3 mm Semi-rigid</p>	 <p>M2-4613</p>	 <p>M2-4621</p>
<p>Median Paramedian Plate, Grid</p> <p>Plate thickness: 1.0 mm Semi-rigid</p>	 <p>M2-4849</p>	

The information provided above is a recommendation only. The operating surgeon is solely responsible for choosing the appropriate implant for the specific case.

Ramus and Angle Fractures

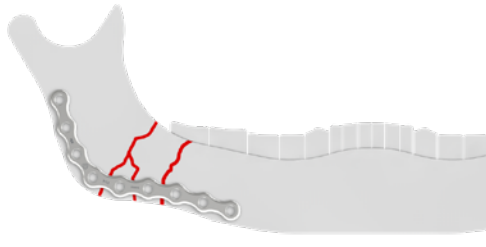
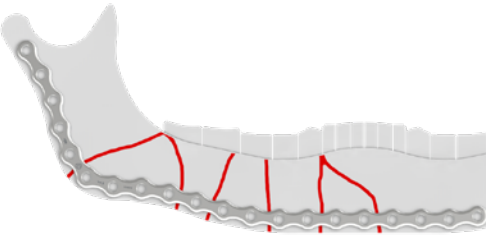
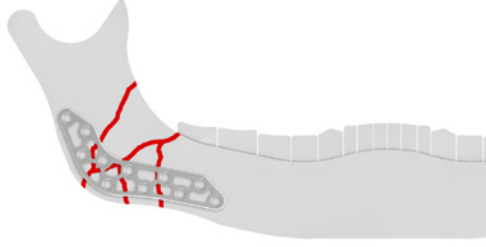
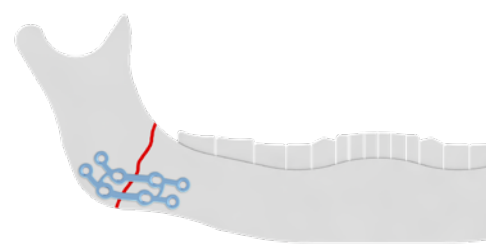
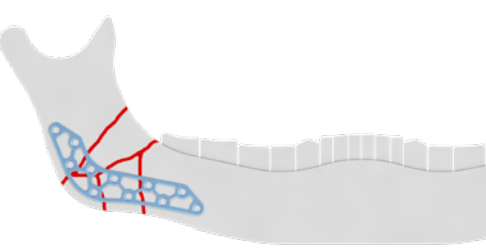
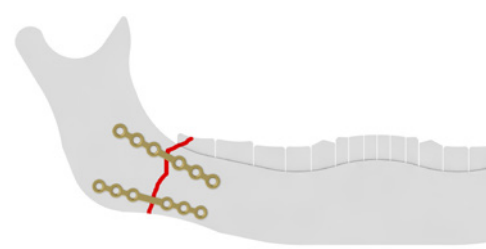
<p>TriLock Plates, Anatomical</p> <p>Plate thickness: 1.5 mm Semi-rigid</p>	 <p>M2-4638 (right) / M2-4637 (left)</p>	 <p>M2-4652 (right) / M2-4651 (left)</p>
<p>TriLock Mandibular Angle Plate, Grid</p> <p>Plate thickness: 1.3 mm Semi-rigid</p>	 <p>M2-4618 (right) / M2-4617 (left)</p>	
<p>Mandibular Angle Plates, Grid</p> <p>Plate thickness: 1.0 mm Semi-rigid</p>	 <p>M2-4856 (right) / M2-4843 (left)</p>	 <p>M2-4848 (right) / M2-4847 (left)</p>
<p>Mandible Plates, Straight</p> <p>Plate thickness: 1.0 mm Rigid</p>	 <p>M2-4324 / M2-4384</p>	

The information provided above is a recommendation only. The operating surgeon is solely responsible for choosing the appropriate implant for the specific case.

Atrophic Mandible Fractures

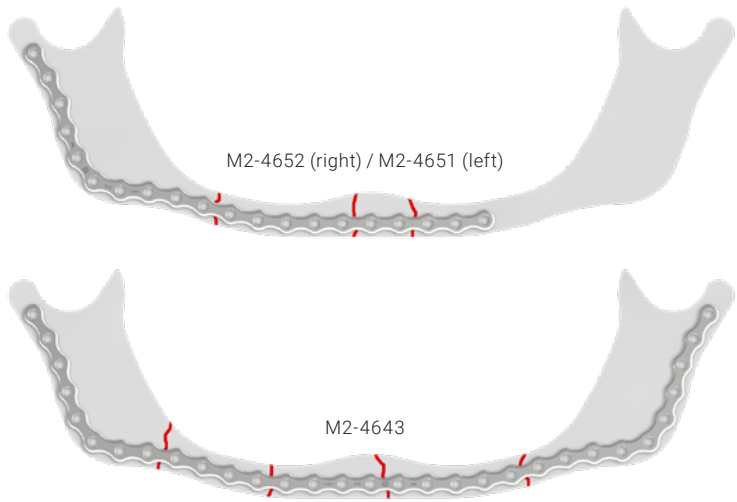
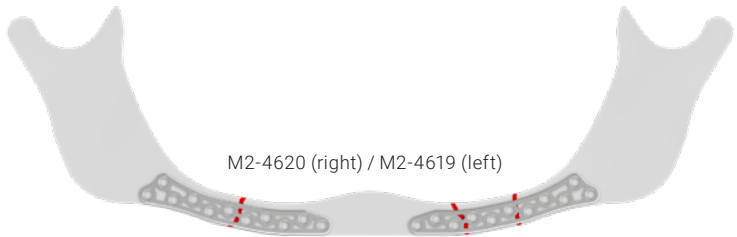
<p>TriLock Plates, Anatomical</p> <p>Plate thickness: 1.5 mm Semi-rigid</p>	 <p>M2-4652 (right) / M2-4651 (left)</p> <p>M2-4643</p>
<p>TriLock Pencilbone Plates, Grid</p> <p>Plate thickness: 1.3 mm Semi-rigid</p>	 <p>M2-4620 (right) / M2-4619 (left)</p>







The information provided above is a recommendation only. The operating surgeon is solely responsible for choosing the appropriate implant for the specific case.

HCL Defect Classification*

Central defects including both canines are designated "C".

Lateral segments that exclude the condyle are designated "L".

Resecting the condyle along the lateral mandible, the defect is designated "H" (hemimandibular).

Classification	Examples of Defects
C (Central)	
L (Lateral)	
H (Hemi- mandibular)	
HC	
HC	
LCL	
HCL	

* according to Jewer et al., 1989

Reconstruction

<p>TriLock Plates, Anatomical</p> <p>Plate thickness: 1.5 mm Semi-rigid</p>	 <p>H M2-4652 (right) / M2-4651 (left)</p> <p>LCL M2-4643</p>
<p>TriLock Plates, Grid</p> <p>Plate thickness: 1.3 mm Semi-rigid</p>	 <p>LCL M2-4621 (centered) M2-4618 (right) / M2-4617 (left)</p> <p>H M2-4613 (centered), M2-4617 (left)</p>
<p>Mandible Plates, Straight</p> <p>Plate thickness: 1.0 mm Rigid</p>	 <p>LCL M2-4300</p>

The information provided above is a recommendation only. The operating surgeon is solely responsible for choosing the appropriate implant for the specific case.

Bridging of a Bone Defect

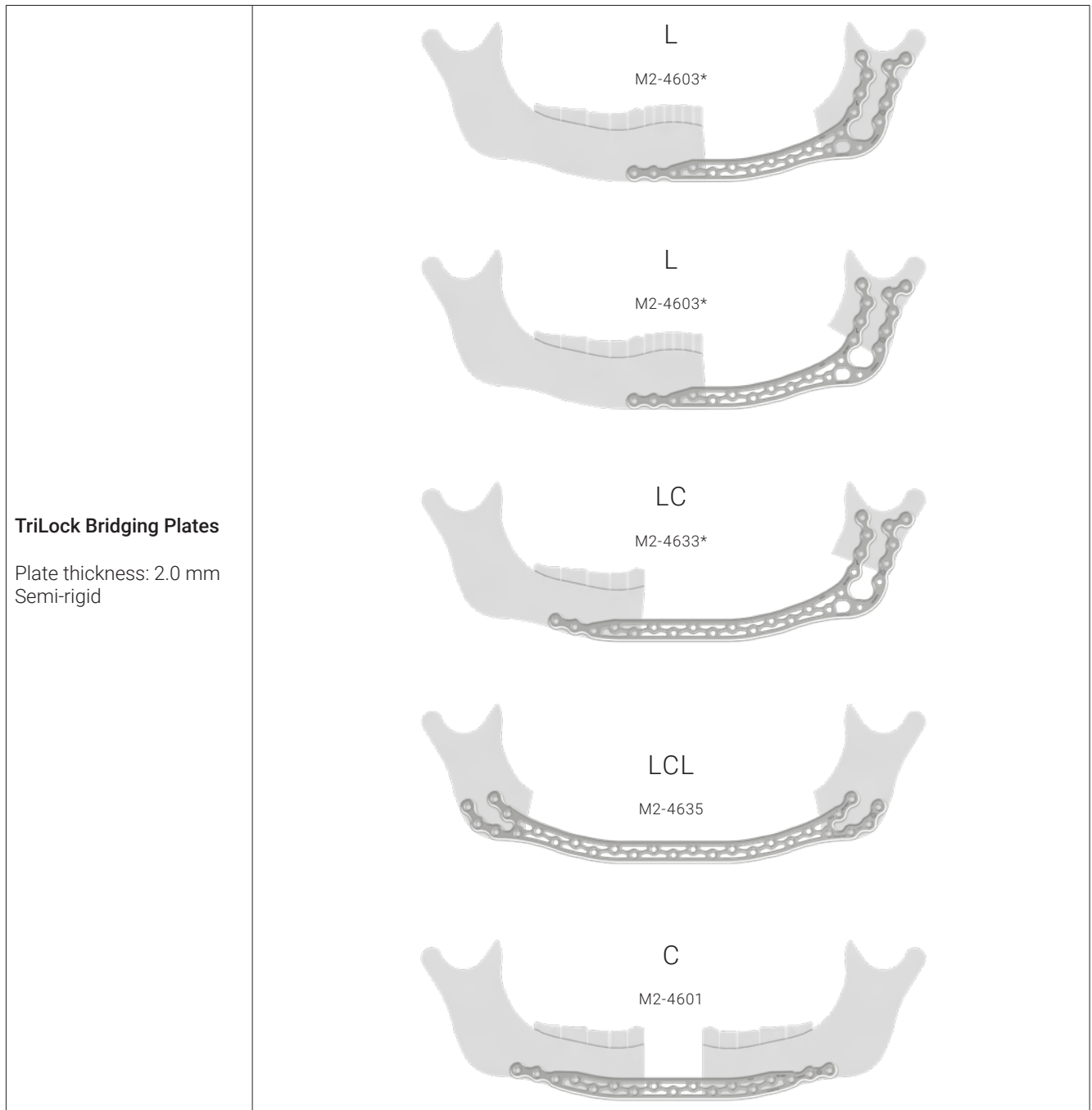

* Double-sided

The information provided above is a recommendation only. The operating surgeon is solely responsible for choosing the appropriate implant for the specific case.

Instrument Application

General Instrument Application

Picking up the Plates

The use of the angled plate and screw holding forceps (M-2009 or M-2019) is recommended to remove the plates. Hold the plate with the forceps as close as possible to the plate-holding pin with spring and pull out of the holder from above.

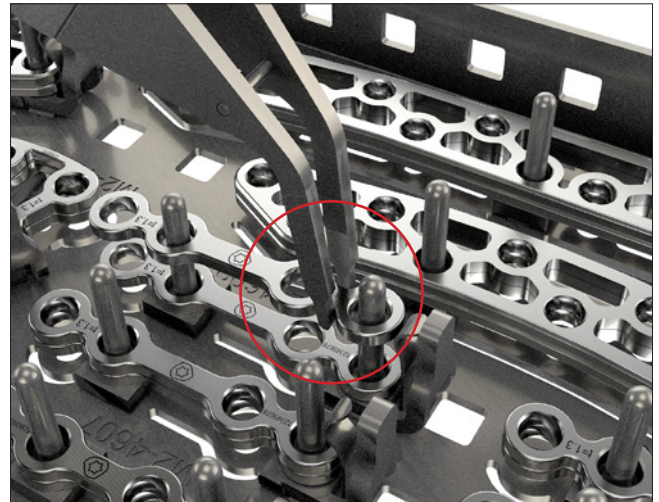

Cutting the Plates

The “cut before bending” principle applies.

There are two different types of cutting pliers which can be used to cut MODUS 2 Mandible plates:

Type 1: Plate cutting pliers (M2-2116) to $t \leq 2.0$ mm

Type 2: Plate cutting pliers (A-2045) to $t \leq 2.0$ mm

Warning

Wrong cutting of the plate may result in sharp edges and lead to injuries of the surrounding tissues.

Type 1

All MODUS 2 Mandible plates can be cut with the M2-2116 cutting pliers.

Ensure that there are no remaining plate segments in the cutting pliers (visual check). Hold the implantable plate segment with your hand during and after cutting.

Insert the plate from the left into the open cutting pliers. The hole countersinks must face upward.

Notice

To facilitate the insertion of the plate, support the cutting pliers gently with your middle finger.

You can visually check the desired cutting line through the cutting window in the head of the pliers (see figure). Always leave enough material on the rest of the plate to keep the adjacent hole intact. The cutting process rounds off the cut edge. The visible part of the plate corresponds to the desired plate length.

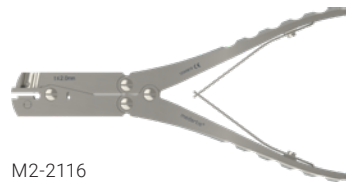

M2-2116
Plate Cutting Pliers $t \leq 2.0$ mm



A-2045
2.0–3.5 Plate Cutting Pliers

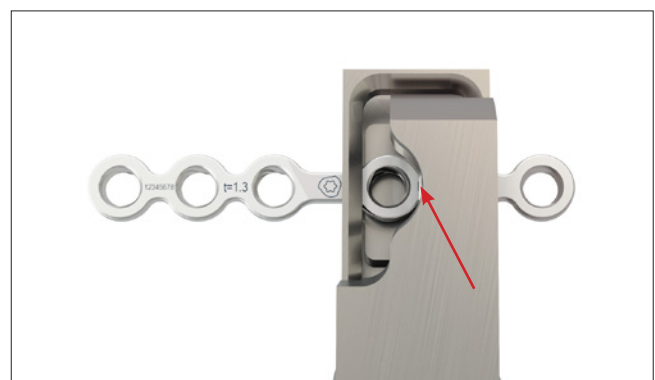

Type 2

All MODUS 2 Mandible plates can be cut with the cutting pliers A-2045. Ensure that there are no remaining plate segments in the cutting pliers (visual check). Insert the plate from the front into the open cutting pliers. The hole countersinks must face upward.

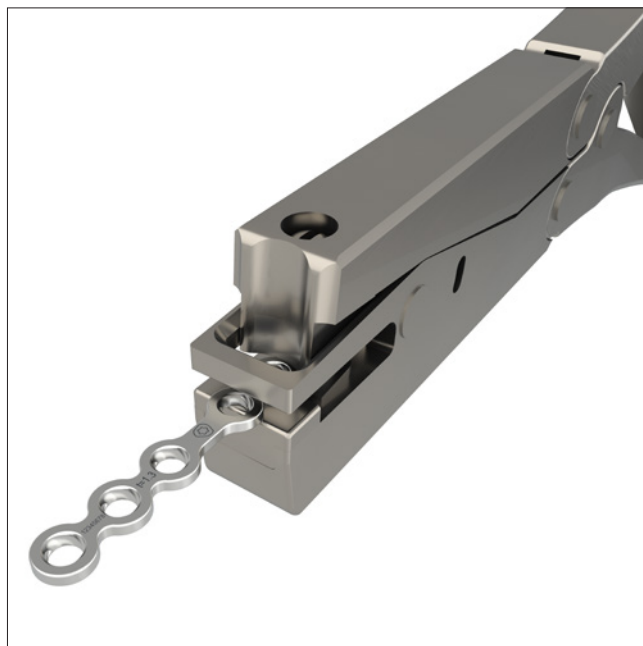

Notice

To facilitate the insertion of the plate, support the cutting pliers gently with your middle finger.



You can visually check the desired cutting line through the cutting window in the head of the pliers (see figure). Always leave enough material on the rest of the plate to keep the adjacent hole intact. The cutting process rounds off the cut edge. The visible part of the plate corresponds to the desired plate length.

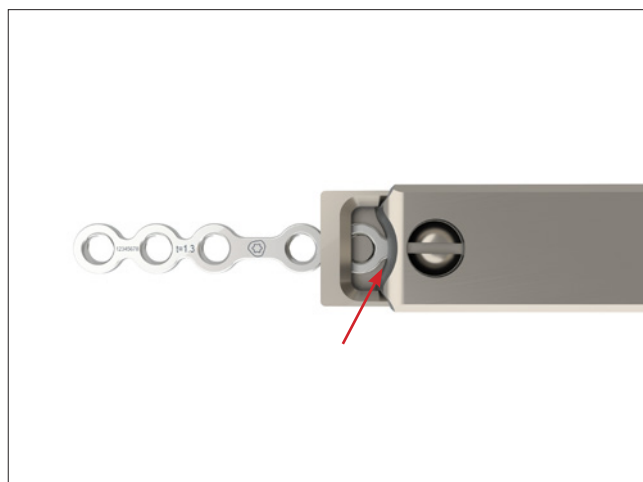

Caution

When cutting with both types of pliers, keep your hand loosely around the pliers to ensure that no parts fly off.

**Caution**

Do not cut grid plates in the grid area.

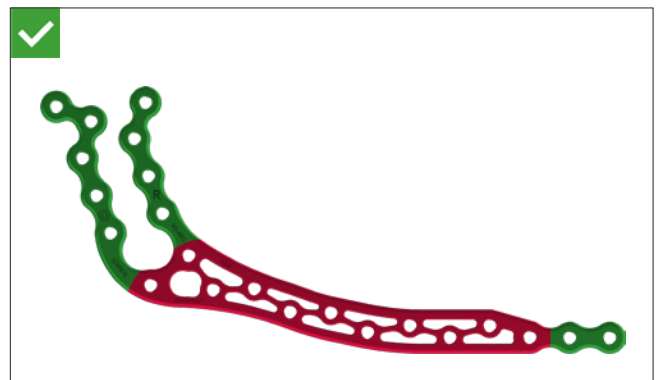

TriLock bridging plates M2-4603/M2-4633 used in combination with the C-adaption M2-4639S are an exception to this rule. In this case the grid structure can be cut as the C-adaption provides stability.



Bending the Plates

If necessary, the MODUS 2 Mandible plates can be bent. There are various options available for this.

Warning

Wrong bending of the plate may lead to impaired functionality and postoperative construct failure.

Plate Bending Pliers with Pin 2.0–2.5 (M2-2158)

Simultaneous bending in multiple planes (3D).

Application: All MODUS 2 Mandible plates

The plate bending pliers with pin are always used in pairs.

To ensure that the TriLock plates lock, they may only be bent with the plate bending pliers with pin (M2-2158).

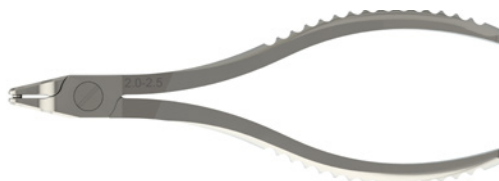

M2-2158
2.0-2.5 Plate Bending Pliers with Pin

Plate Bending Pliers, Flat Nose (M2-2000)

Simultaneous bending in multiple planes (3D).

Application: All non-locking MODUS 2 Mandible fixation plates.



M2-2000
Plate Bending Pliers, Flat Nose

Plate Bending Pliers 2.0–2.5 (M2-2006)

Flat plier function, bending outside the plane, bending within the plane.

Application: All non-locking MODUS 2 Mandible fixation plates.



M2-2006
2.0-2.5 Plate Bending Pliers

Simultaneous bending in multiple planes – 3D (fixation plates and TriLock plates)

Take the plate and define at the mandible where to start the bending process.



Hold the plate bending pliers with pin (M2-2158) so that the pin enters the plate hole from above (with the "UP" marking on the plate bending pliers pointing upward). Always insert the TriLock plates into the plate bending pliers with the markings facing upward. The purpose of this process is to protect the plate hole from deformities.



While bending, the plate must always be held at two adjacent holes to prevent contour deformation of the intermediate plate hole.



Regularly check the curvature of the plate to prevent overbending and thereby excess strain on the plate.



Warning

Repeatedly bending the plate in opposite directions may cause the plate to break postoperatively. Always use the provided plate bending pliers to avoid damaging the plate holes. Damaged plate holes prevent correct and secure seating of the screw in the plate and increase the risk of system failure.

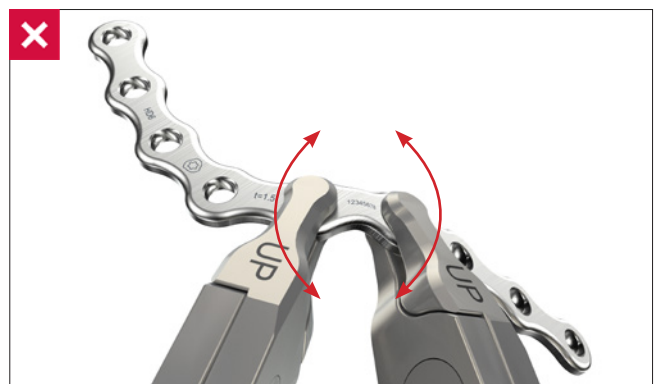

Warning

Do not bend plates without a bar by more than 30°. Bending the plate further may deform the plate holes and may cause the plate to break postoperatively.

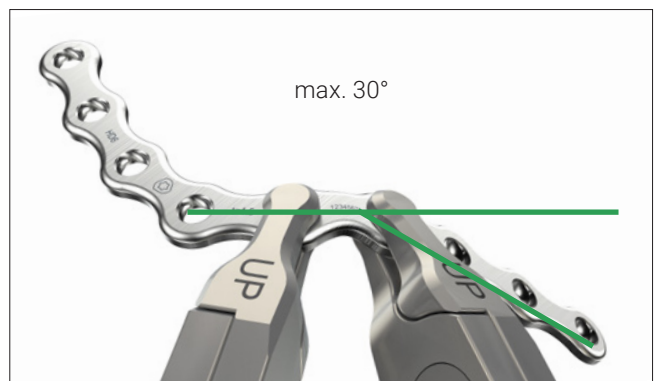

The bending pliers (M2-2158) can also be used to bend all grid plates.



Flat plier function

2.0–2.5 Plate bending pliers, flat nose (M2-2000)

2.0–2.5 Plate bending pliers (M2-2006)

For the non-locking plates, optionally the plate bending pliers with flat nose (M2-2000 and M2-2006) can be used.

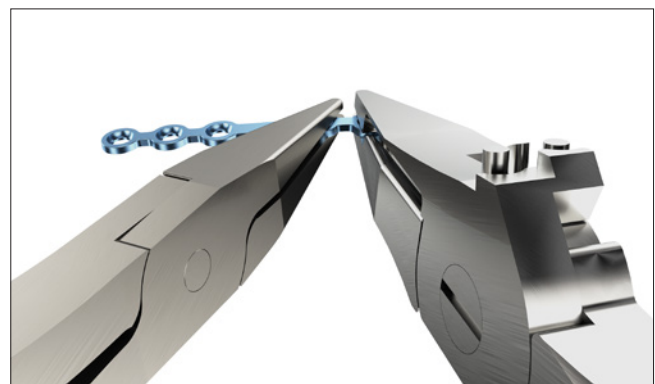

Bending within the plane (Aderer function)

2.0–2.5 Plate bending pliers (M2-2006)

For the cranial plates (plate thickness 1.0 mm), a three-jaw plier function (“Aderer function”) is integrated into the plate bending pliers (M2-2006) so that the plates bend in the plane.

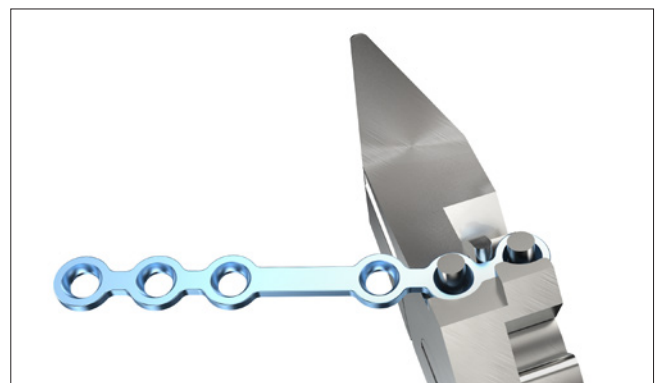

Bending outside the plane

2.0–2.5 Plate bending pliers (M2-2006)

Bars can be bent with the 90° bending function between the jaws of the plate bending pliers.

Position the plate in the pliers between the jaws. The slot permits the plate to be viewed.

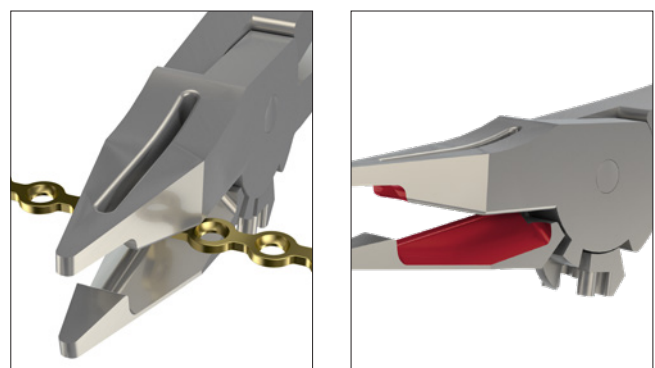

Drilling

Color-coded twist drills are available for each MODUS 2 screw diameter. All drills are color coded with a ring system.

Screw Diameter Color Code

2.0	Blue
2.3	Brown
2.5	Purple

There are two different types of twist drill: Core hole drills are marked with one colored ring and gliding hole drills (for lag screw technique) are marked with two colored rings.

Core Hole Drills

Drills for screws \varnothing 2.0 (drill \varnothing 1.5)

Dental	Stryker	
M2-3119	M2-3129	5 mm
M2-3139	M2-3149	7 mm
M2-3159	M2-3169	25 mm



Drills for screws \varnothing 2.3 (drill \varnothing 1.9)

Dental	Stryker	
M2-3176	M2-3186	7 mm
M2-3196	M2-3206	25 mm



Drills for screws \varnothing 2.5 (drill \varnothing 2.0)

Dental	Stryker	
M2-3236	M2-3246	7 mm
M2-3256	M2-3266	25 mm



Gliding Hole Drills

Drills for screws \varnothing 2.0 (drill \varnothing 2.0)

Dental	Stryker	
M2-3156	M2-3166	25 mm



Drills for screws \varnothing 2.3 (drill \varnothing 2.3)

Dental	Stryker	
M2-3336	M2-3346	25 mm



Drilling with Drill Guide

The 2.0–2.5 drill guide (M2-2198) can be used for MODUS 2 Mandible TriLock plates and fixation plates.

After positioning the plate, insert the drill guide and the twist drill into the screw hole. The drill is guided by the shaft of the drill and not the drill flute.

Drills for use in combination with the drill guide:

Core Hole Drills

Drills for screws \varnothing 2.0 (drill \varnothing 1.5)

Dental	Stryker	
M2-3459	M2-3469	25 mm

Drills for screws \varnothing 2.3 (drill \varnothing 1.9)

Dental	Stryker	
M2-3216	M2-3226	25 mm

Drills for screws \varnothing 2.5 (drill \varnothing 2.0)

Dental	Stryker	
M2-3276	M2-3286	25 mm

Gliding Hole Drills

Drills for screws \varnothing 2.0 (drill \varnothing 2.0)

Dental	Stryker	
M2-3296	M2-3306	25 mm

Drills for screws \varnothing 2.3 (drill \varnothing 2.3)

Dental	Stryker	
M2-3316	M2-3326	25 mm

Warning

For TriLock plates ensure that the screw holes are predrilled with a pivoting angle of no more than $\pm 15^\circ$. For this purpose, the drill guides feature a limit stop at $\pm 15^\circ$. A predrilled pivoting angle of $> 15^\circ$ no longer allows the TriLock screws to correctly lock in the plate.

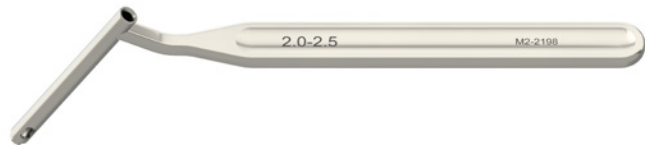

M2-2198
2.0–2.5 Drill Guide



M2-3459



M2-3216



M2-3276



M2-3296



M2-3316



Assigning the Screw Length

The 2.0–2.5 depth gauge (M2-2260) is used to determine the ideal screw length for use in monocortical or bicortical screw fixation.



M2-2260
2.0–2.5 Depth Gauge

Retract the slider of the depth gauge.



The caliper of the depth gauge has a hooked tip that is either inserted to the bottom of the hole or is used to catch the far cortex of the bone. When using the depth gauge, the caliper stays static and only the slider is adjusted.



To assign the screw length, place the distal end of the slider onto the implant plate.

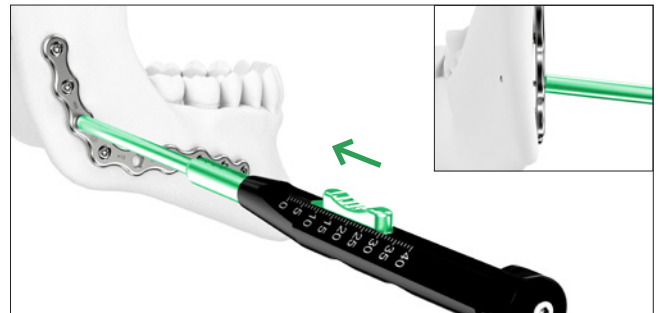

The ideal screw length for the assigned drill hole can be read on the scale of the depth gauge.

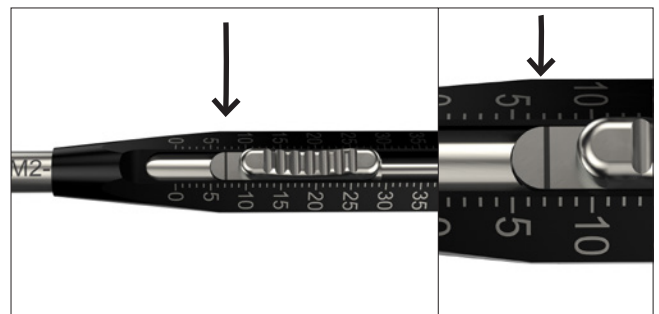

Screw Pick-Up

The screwdriver handles (M2-2001 and M2-2040) are compatible with the screwdriver blade (M2-2005). The screwdriver blade (M2-2005) features the patented self-holding technology HexaDrive.



M2-2001
Type 2 Screwdriver Handle



M2-2040
Type 3 Screwdriver Handle



M2-2005
Screwdriver Blade, HD6, 95 mm

Notice

All screws up to 7 mm in length are secured with a securing element. To remove these screws, turn the securing element to the right with the screwdriver. This releases the screws.

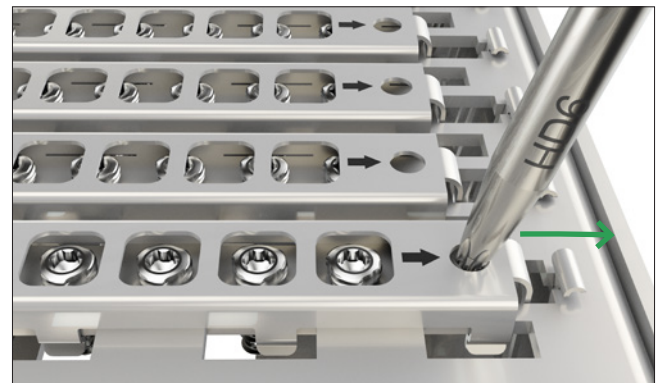

To remove the screws from the implant container, insert the appropriately color-coded screwdriver blade perpendicularly into the screw head of the desired screw and pick up the screw with axial pressure.

Notice

The screw will not hold without axial pressure.

Caution

Vertically extract the screw from the compartment. Picking up the screw repeatedly may lead to permanent deformation of the self-retaining area of the HexaDrive inside the screw head. Therefore, the screw may no longer be able to be picked up correctly. In this case, a new screw has to be used.

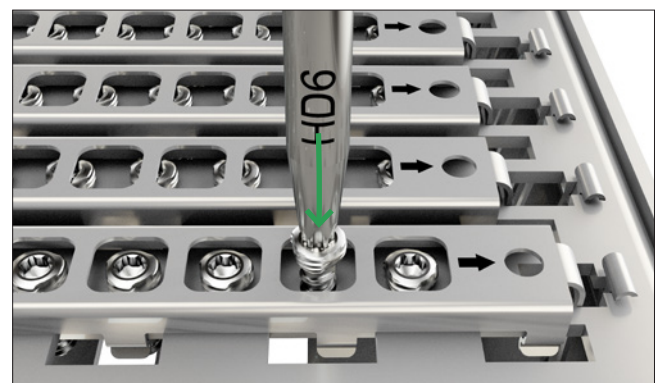

Notice

The screw length is checked with the measuring module and read at the end of the screw head.

Check the correct screw diameter: The screw can be inserted into the hole of the appropriate screw diameter. The screw will not fit in the hole for the next screw size down.

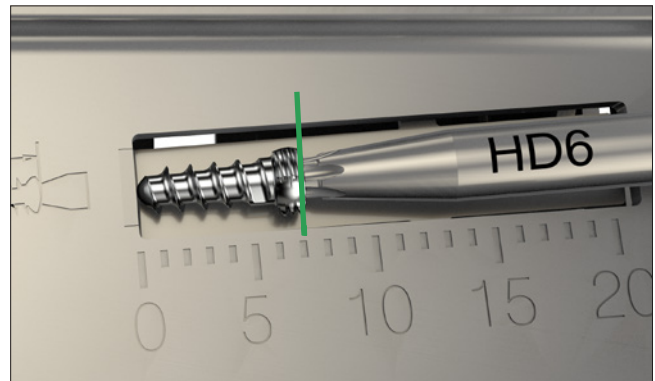

Notice

Check 2.0 SpeedTip screws in the hole \varnothing 2.3.



Notice

After removing screws up to a length of 7 mm it is important to ensure that the securing elements are closed again to prevent the screws from dropping out. To do this, lightly press down on the outer left of the securing element and it will close of its own accord.

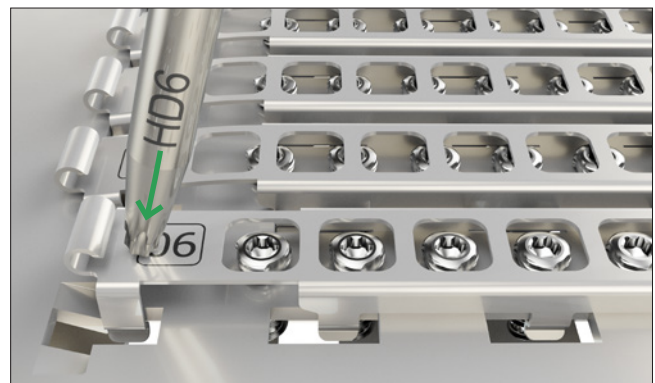

Screws secured with a securing element cannot be directly removed with the 90° screwdriver.

The screws must be removed with the screwdriver blade and stored temporarily in the screw measuring module. From here the screw can be picked up with the 90° screwdriver.



Specific Instrument Application

Bending of TriLock Bridging Plates

Three-point bending pliers (M2-2016)

Bending of grid plates out of the plane.

Application: All MODUS 2 Mandible plates with grid structure (plate thickness 1.0–2.0 mm).

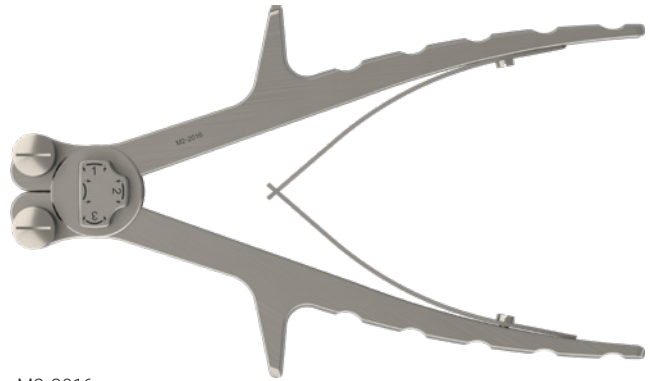

M2-2016
2.0–2.5 Three-Point Bending Pliers

Ramus plate bending instrument (M2-2026)

Adjustment of the ramus section of the TriLock bridging plates and the TriLock plates.

Application: All MODUS 2 Mandible TriLock bridging plates (plate thickness 2.0 mm) and TriLock plates (plate thickness 1.5 mm)



M2-2026
Ramus Plate Bending Instrument

Warning

Wrong bending of the plate may lead to impaired functionality and postoperative construct failure.

Bending template (example M2-4669)

1. Bending the template

Use the template, which can easily be bent manually, to replicate the shape of the mandible. This design will be transferred to the corresponding TriLock bridging plate.

Notice

The templates may not be placed on top of each other in the container.



M2-4669
Template for M2-4633

Place the template in the ramus section.

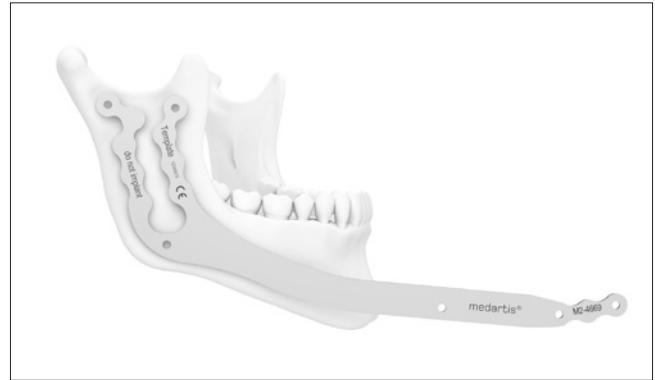

Adjust the angle of the two arms to the mandibular angle.

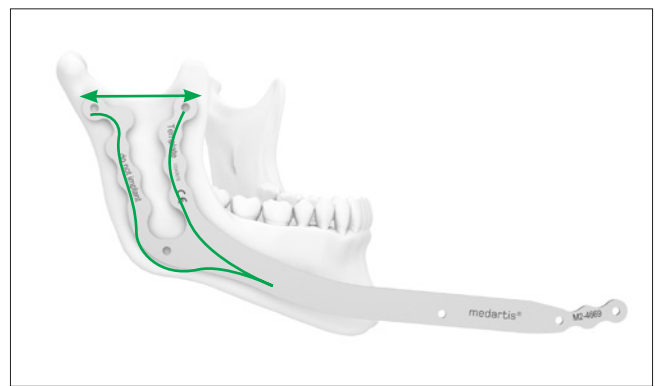

Bend the template along the mandible, starting at the ramus section.



Bent template.



2. Bending the plate

Adjust the ramus section of the plate to the template.

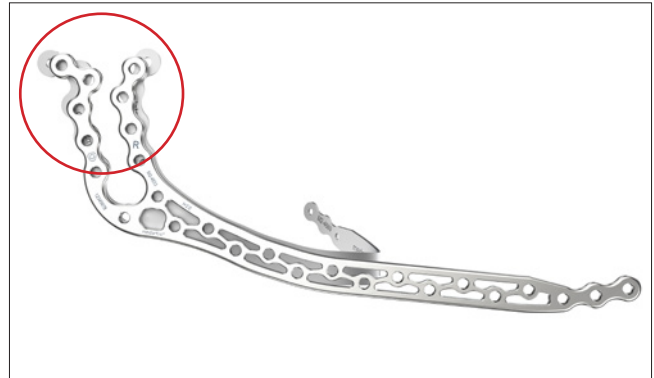

Use the ramus bending instrument (M2-2026) to bend the ramus section.

Notice

Two ramus bending instruments can be used for simultaneously bending the anterior and posterior arms.

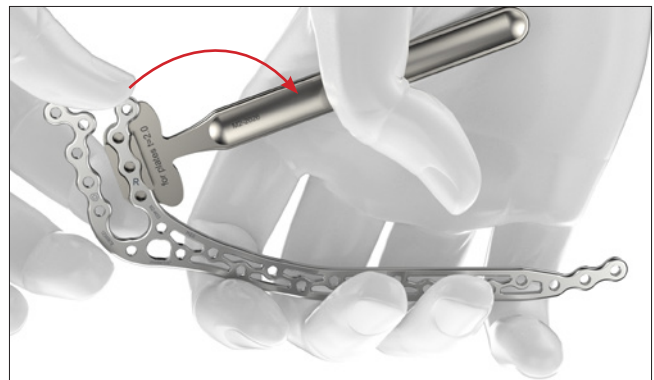

Check the shape of the plate and bend again if necessary.

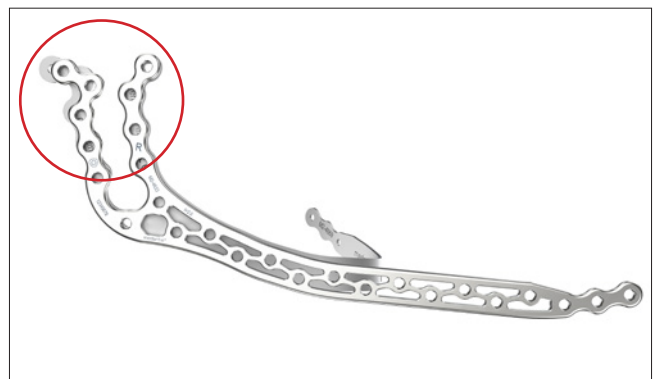

Final fitting of the ramus section of the plate (in situ or on the planning model).

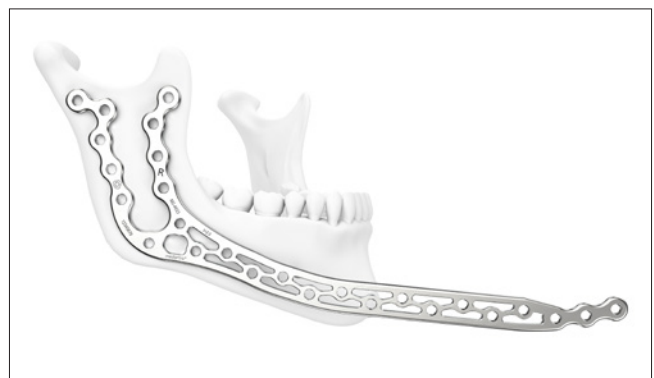

Notice

The length of the ramus section of the plate can be cut to fit the patient's anatomy (use of M2-2116, see section "Cutting the Plates").

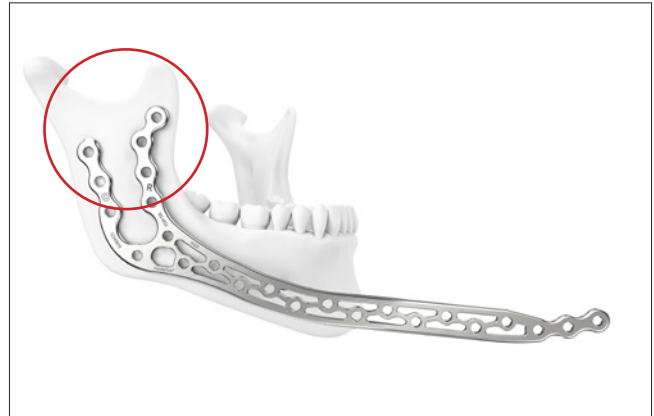

Final shape of the ramus section.

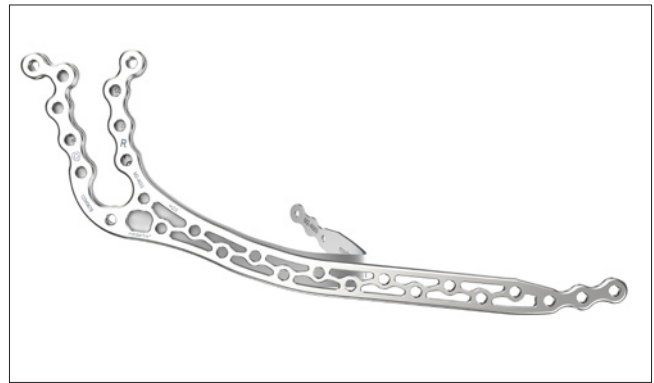

Adjust the three-point bending pliers (M2-2016) to the starting position (1) before starting the bending process.

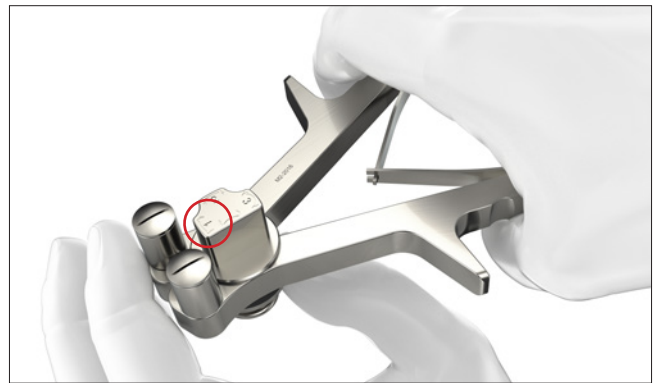

Hold the plate to the template to define the start of the bending.

Notice

Always start bending at the ramus end of the plate.

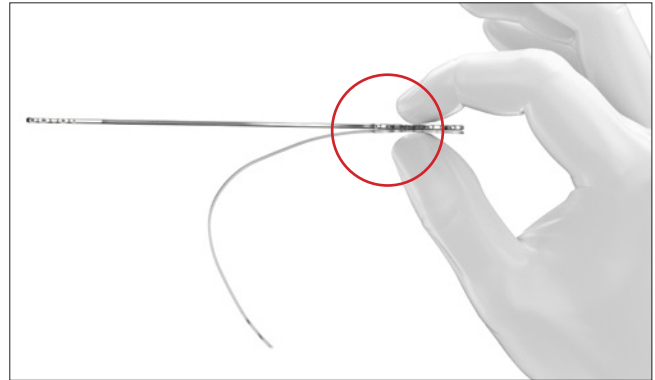

Start bending in position 1 (slight bending).

**Caution**

During the entire bending process, the bridging plate must be placed in the bending pliers so that the anterior grid section is parallel to the contact surface of the bending pliers.

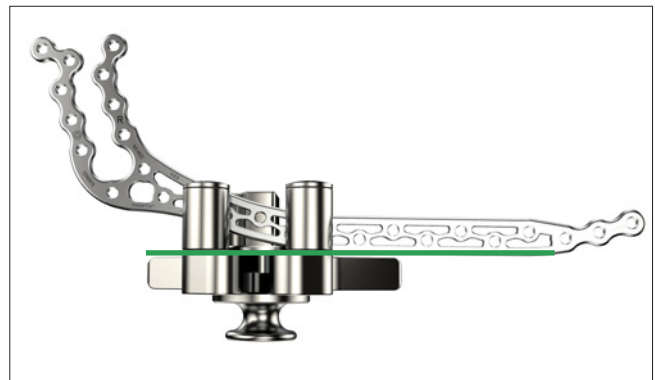

Control the bending and use position 2 (moderate bending) of the bending pliers to continue if necessary.

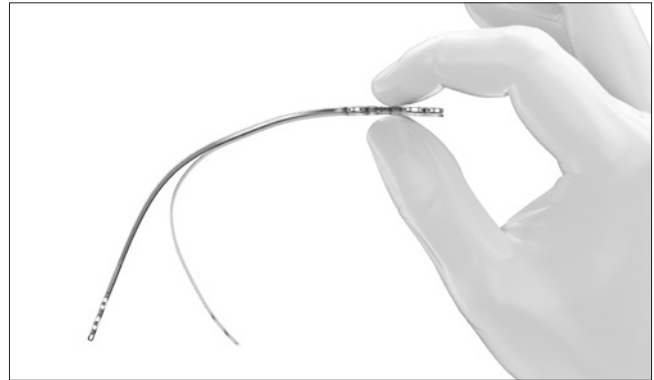

Check the shape and finalize bending in position 3 (strong bending) if necessary.

Notice

It will not always be necessary to use all three bending positions.

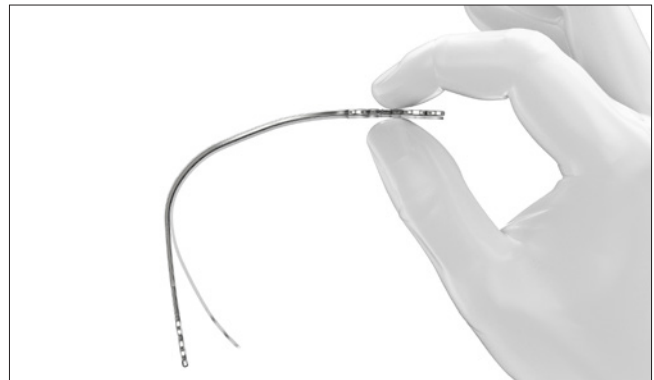

Check the final shape of the plate before implantation (in situ or on the planning model).



Surgical Techniques

General Surgical Techniques

Lag Screw Technique

Warning

Incorrect application of the lag screw technique may result in postoperative loss of reduction.

1. Drilling the core hole

Use the core hole drill (one colored ring) of the same screw diameter to drill to the far cortex.

2. Drilling the gliding hole

Use the gliding hole drill (two colored rings) to drill up to the fracture line.

3. Compressing

Compress with the cortical screw of the corresponding screw diameter.

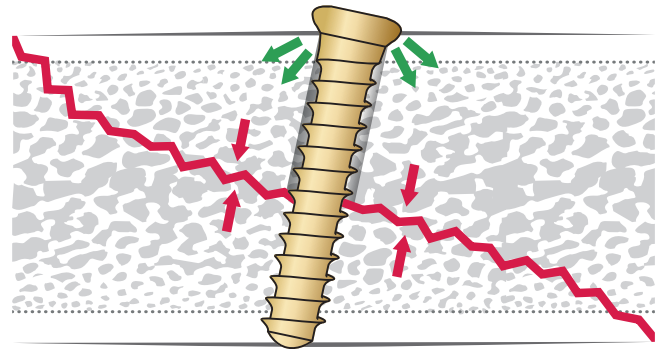

Specific Surgical Techniques

Assembly of the C-Adaption for Bridging Plates

The TriLock bridging plates (M2-4603, M2-4633) can be used in combination with the C-adaption (M2-4639S). Pre-operatively the plates have to be cut (see section "Cutting the Plates") and bent (see section "Bending the Plates") to fit the patient's anatomy.



M2-5268.05S
Connecting Screw for
M2-4639S



M2-4639S
C-Adaption for Bridging
Plates

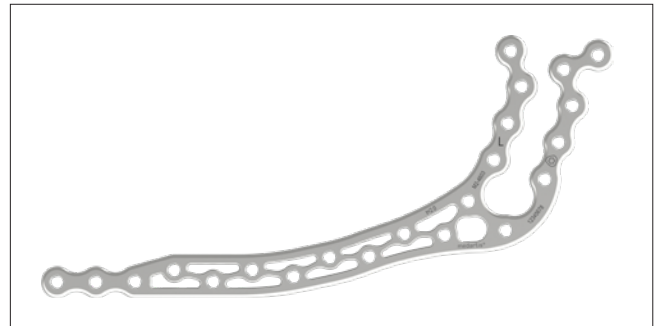

Use the preformed template (see section "Bending of TriLock Bridging Plates") to determine the cutting line on the plate. Use the plate cutting pliers (M2-2116) to obtain a cut without sharp edges.

Caution

Always cut before bending.

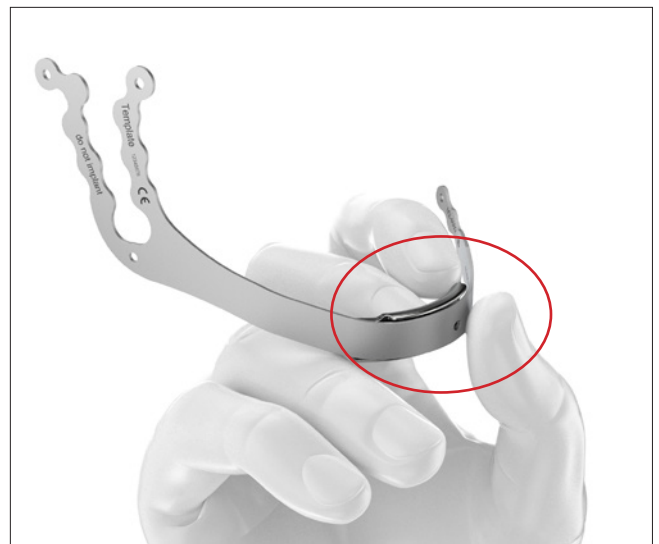
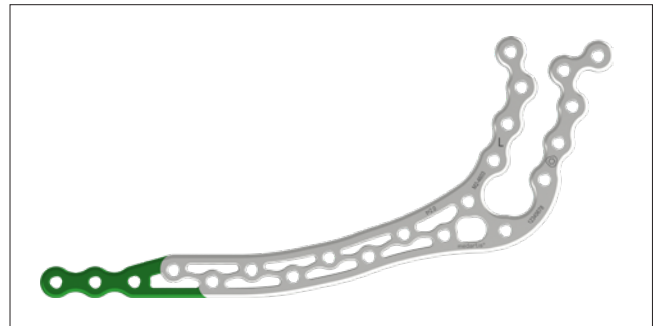

The short “lip” of the C-adaption has to point upward ↑, to avoid collision with the shaped plates during the assembly.



Warning

Make sure to insert at least 3 screws per side.

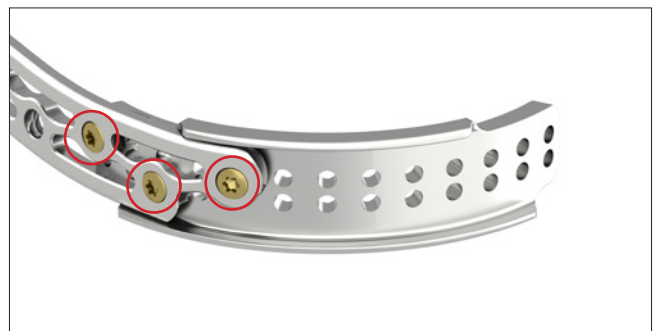

Assembled C-adaption.

Notice

2.5 TriLock screws have to be used for bridging of bone defects.

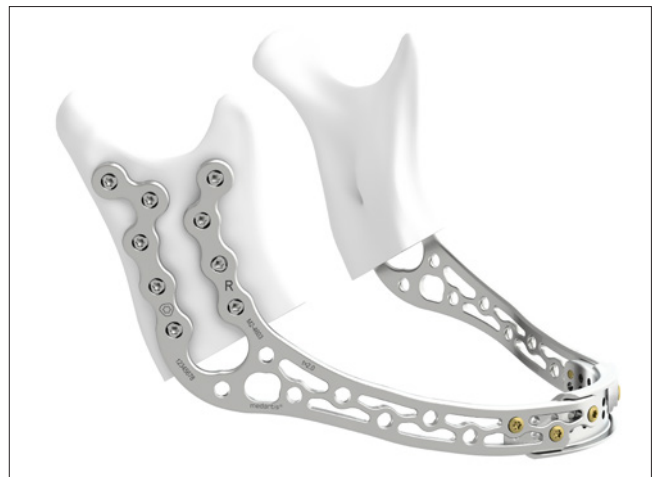

Use of the Temporary Locking Stopper for TriLock Screws

When using locking plates, it is not possible to pull the plate onto the bone with TriLock screws as these are locked in the plate when they come into contact with the locking mechanism and therefore cannot build up any traction. The locking stopper for TriLock screws can be used with all 2.0/2.3/2.5 TriLock screws.



M2-2007
Temporary Locking Stopper TriLock Screws

Position the prepared plate in situ. Drill the first hole close to the fracture and insert the TriLock screw with a distance to the plate.

Notice

The use of TriLock screws with a minimum length of 7 mm is recommended to ensure that the locking stopper can be inserted correctly.



Position the locking stopper over the screw head.



Tighten the screw. The locking stopper prevents locking and the plate is drawn towards the bone.



Drill the remaining holes and insert TriLock screws.



Loosen the screw in the locking stopper and remove the locking stopper. Then lock the last screw.



Follow-Up Care and Explantation

Follow-Up Care for MODUS 2 Mandible Implants

Taking into account the individual fracture conditions and patient compliance, it is important to ensure adequate postoperative relief of the osteosynthesis in terms of adaptation or mobilization stability (e.g. splinting and/or immobilization). Postoperatively, the fixation achieved with the implants must be treated with care until the bone has fully healed. Patients must strictly observe follow-up instructions given by their physicians to avoid detrimental strain on the implants. Early load bearing can increase the risk of loosening, migration or breakage of the implants.

Explantation of MODUS 2 Mandible Implants

Use the appropriate screwdrivers to remove the screws to explant MODUS 2 implants.

Caution

Only original MODUS 2 instruments are recommended for the explantation of MODUS 2 implants. When removing the screws, ensure that any bone ingrowth in the screw head has been removed, that the screwdriver/screw head connection is aligned in axial direction, and that a sufficient axial force is used between blade and screw.

TriLock Locking Technology

Correct Application of the TriLock Locking Technology

The screw is inserted through the plate hole into a predrilled canal in the bone. An increase of the tightening torque will be felt as soon as the screw head makes contact with the plate surface.

This indicates the start of the "Insertion Phase" as the screw head starts entering the locking zone of the plate (section "A" in the diagram). Afterwards, a drop of the tightening torque

occurs (Section "B" in the diagram). Finally, the actual locking is initiated (section "C" in the diagram) as a friction connection is established between screw and plate when tightening firmly.

The torque applied during fastening of the screw is decisive for the quality of the locking as described in section "C" of the diagram.

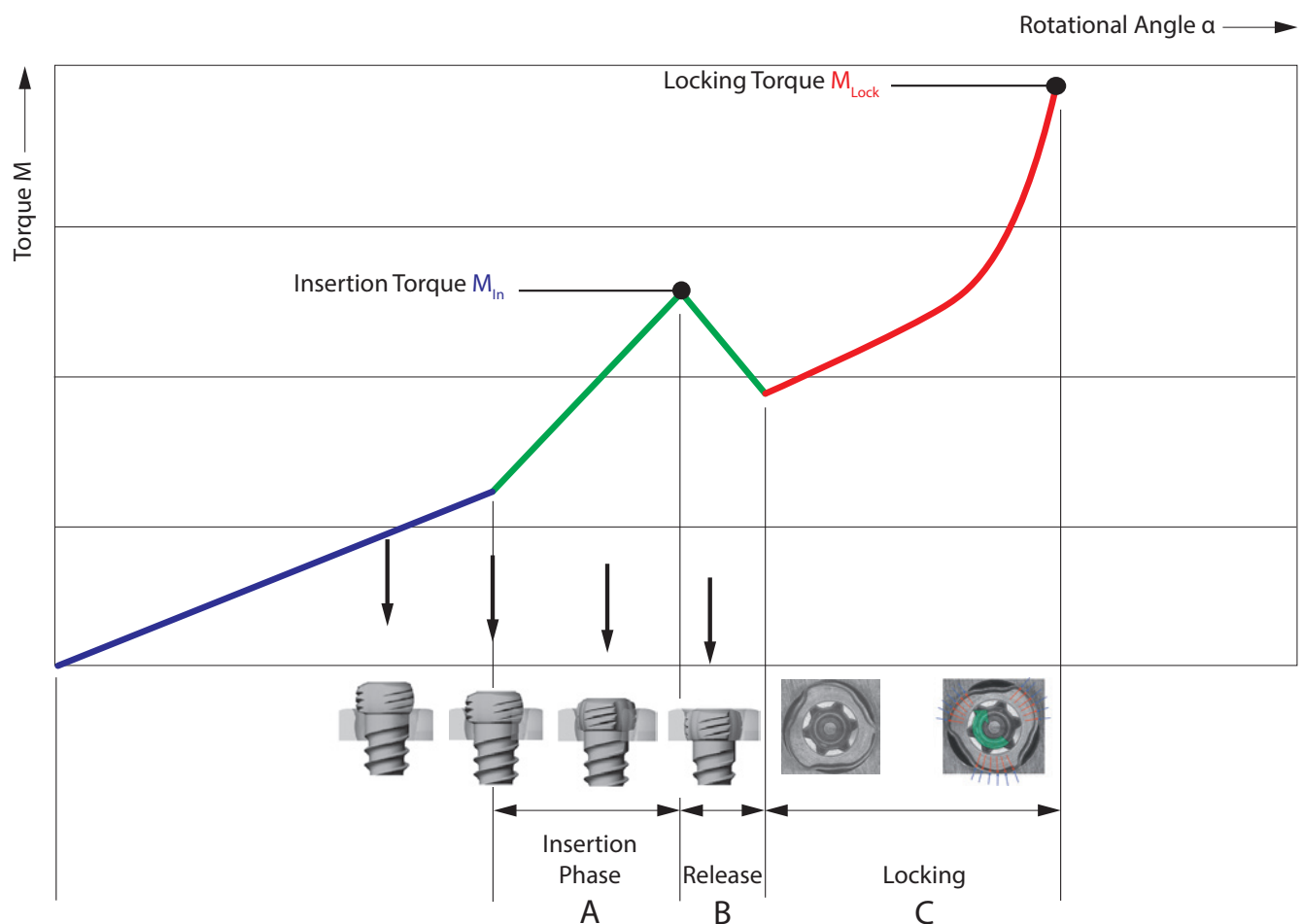

Correct Locking ($\pm 15^\circ$) of the TriLock Screws in the Plate

Correct locking occurs only when the screw head is locked flush with the locking contour (fig. 1 and 3).

However, if there is still a noticeable protrusion (fig. 2 and 4), the screw head has not completely reached the locking position. In this case the screw has to be retightened to obtain full penetration and proper locking. In case of poor bone quality, slight axial pressure may be necessary to

achieve proper locking. Due to the system characteristics, a screw head protrusion of around 0.2 mm exists when using plates with 1.0 mm thickness.

After having reached the locking torque (M_{Lock}), do not further tighten the screw, otherwise the locking function cannot be guaranteed anymore.

Correct: LOCKED

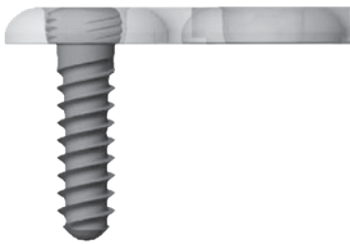

Figure 1

Incorrect: UNLOCKED

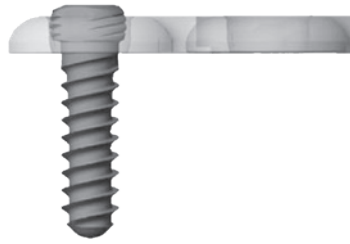

Figure 2

Correct: LOCKED

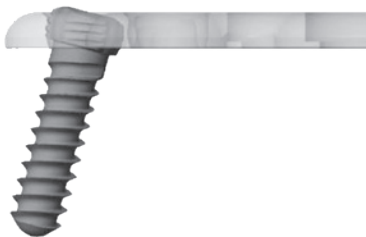

Figure 3

Incorrect: UNLOCKED



Figure 4

Implants, Instrument and Containers

Mandible Plates t = 1.0 mm

Straight Plates

Compatible with screws \varnothing 2.0/2.3

Material: Titanium (ASTM F67)
Plate thickness: 1.0 mm

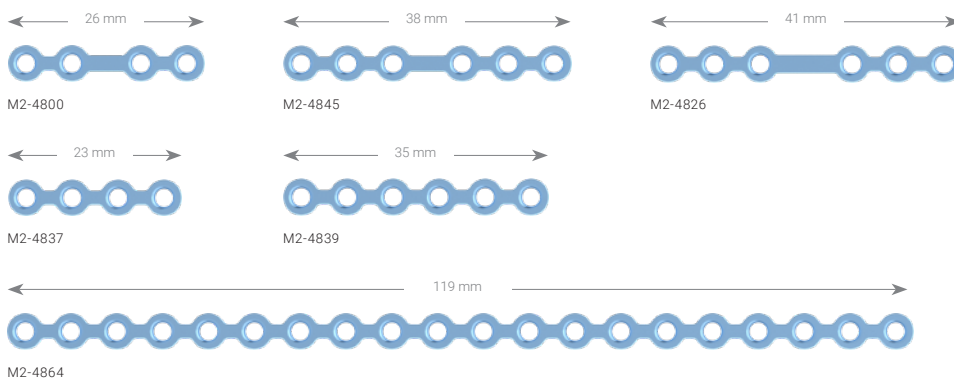

Art. No.	STERILE	Holes	Bar	Pieces / Pkg
M2-4800	M2-4800S	4	9 mm	1
M2-4826	M2-4826S	6	12 mm	1
M2-4837	M2-4837S	4		1
M2-4839	M2-4839S	6		1
M2-4845	M2-4845S	6	9 mm	1
M2-4864	M2-4864S	20		1

Condyle Plates

Compatible with screws \varnothing 2.0/2.3

Material: Titanium (ASTM F67)
Plate thickness: 1.0 mm

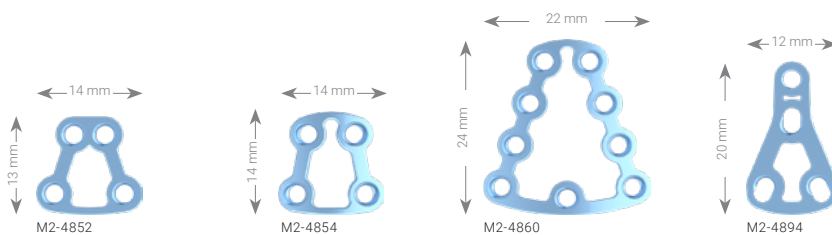

Art. No.	STERILE	Description	Holes	Pieces / Pkg
M2-4852	M2-4852S	TCP, trapezoid	4	1
M2-4854	M2-4854S	TCP, trapezoid, pre-shaped	4	1
M2-4860	M2-4860S	TCP, trapezoid, pre-shaped	9	1
M2-4894	M2-4894S	Delta Condyle Compression Plate	4	1

Mandibular Angle Plates

Compatible with screws \varnothing 2.0/2.3

Material: Titanium (ASTM F67)
Plate thickness: 1.0 mm

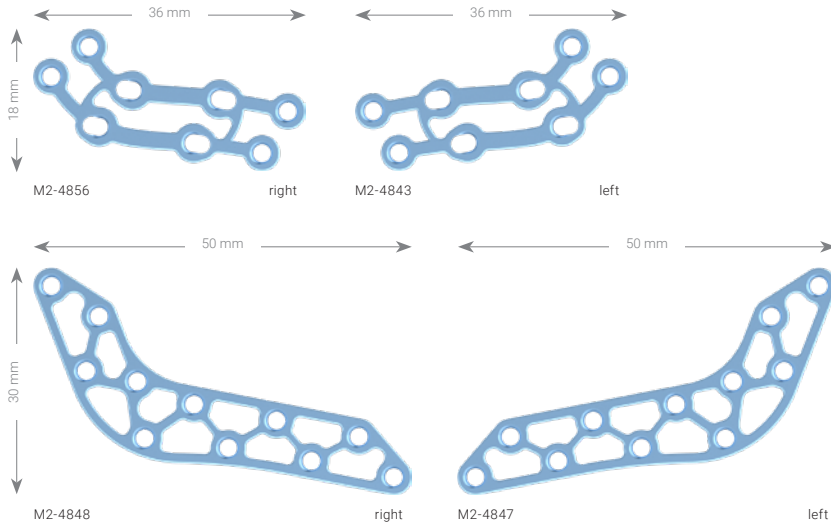

Art. No.	STERILE	Description	Holes	Pieces / Pkg
M2-4843	M2-4843S	left	8 (4+4)	1
M2-4847	M2-4847S	grid, left	11	1
M2-4848	M2-4848S	grid, right	11	1
M2-4856	M2-4856S	right	8 (4+4)	1

Grid Median-Paramedian Plate

Compatible with screws \varnothing 2.0/2.3

Material: Titanium (ASTM F67)
Plate thickness: 1.0 mm

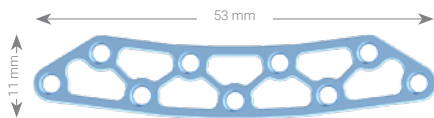

Art. No.	STERILE	Holes	Pieces / Pkg
M2-4849	M2-4849S	9	1

Grid Compression Plates

Compatible with screws \varnothing 2.0/2.3

Material: Titanium (ASTM F67)
Plate thickness: 1.0 mm

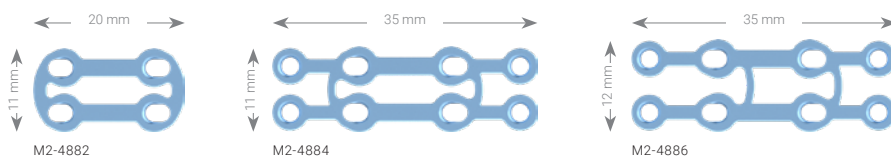

Art. No.	STERILE	Description	Holes	Pieces / Pkg
M2-4882	M2-4882S		4 (2+2)	1
M2-4884	M2-4884S		8 (4+4)	1
M2-4886	M2-4886S	asymmetrical	8 (4+4)	1

Straight Plates

Compatible with screws \varnothing 2.0/2.3

Material: Titanium (ASTM F67)
Plate thickness: 1.0 mm

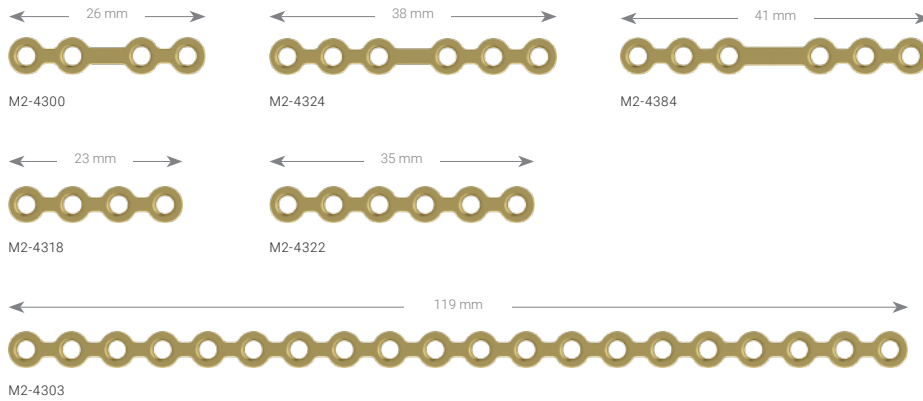

Art. No.	STERILE	Holes	Bar	Pieces / Pkg
M2-4300	M2-4300S	4	9 mm	1
M2-4303	M2-4303S	20		1
M2-4318	M2-4318S	4		1
M2-4322	M2-4322S	6		1
M2-4324	M2-4324S	6	9 mm	1
M2-4384	M2-4384S	6	12 mm	1

Pencilbone Compression Plates

Compatible with screws \varnothing 2.0/2.3

Material: Titanium (ASTM F67)
Plate thickness: 1.0 mm

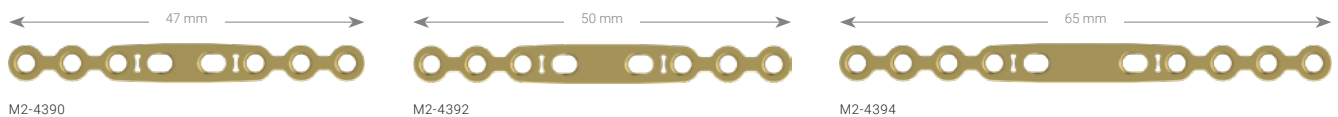

Art. No.	STERILE	Holes	Bar	Pieces / Pkg
M2-4390	M2-4390S	8	6 mm	1
M2-4392	M2-4392S	8	9 mm	1
M2-4394	M2-4394S	10	12 mm	1

Mandible Plates, 70°

Compatible with screws \varnothing 2.0/2.3

Material: Titanium (ASTM F67)
Plate thickness: 1.0 mm

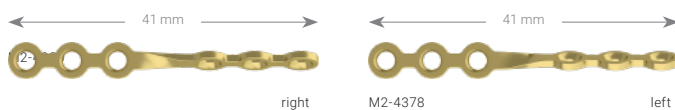

Art. No.	STERILE	Description	Holes	Bar	Pieces / Pkg
M2-4378	M2-4378S	left	6	9 mm	1
M2-4380	M2-4380S	right	6	9 mm	1

Mandible Plates t = 1.3 mm

TriLock Plates, Straight

Compatible with screws \varnothing 2.0/2.3/2.5

Material: Titanium (ASTM F67)
Plate thickness: 1.3 mm

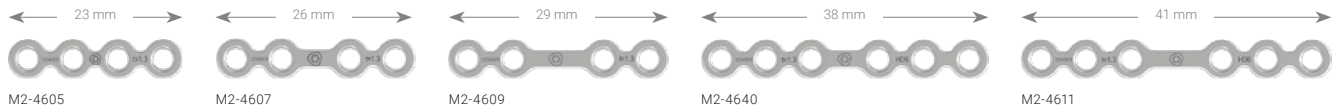

Art. No.	STERILE	Holes	Bar	Pieces / Pkg
M2-4605	M2-4605S	4		1
M2-4607	M2-4607S	4	9 mm	1
M2-4609	M2-4609S	4	12 mm	1
M2-4611	M2-4611S	6	12 mm	1
M2-4640	M2-4640S	6	9 mm	1

TriLock Condyle Plates

Compatible with screws \varnothing 2.0/2.3/2.5

Material: Titanium (ASTM F67)
Plate thickness: 1.3 mm
Plate thickness M2-4692: 1.5 mm

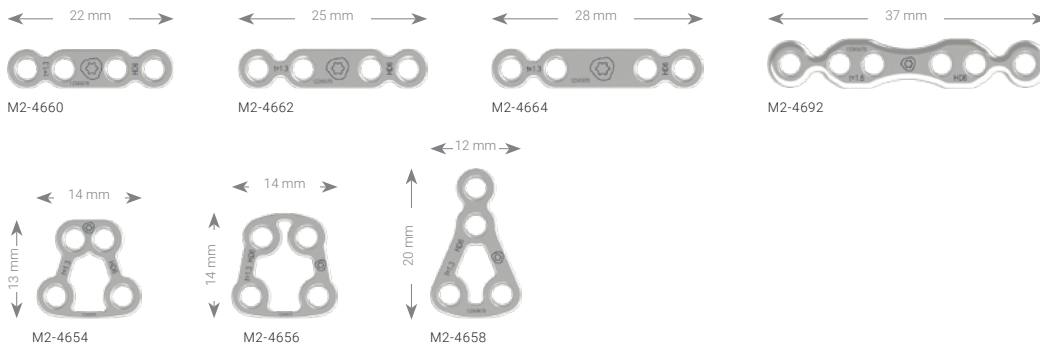

Art. No.	STERILE	Description	Holes	Bar	Pieces / Pkg
M2-4654	M2-4654S	TCP	4		1
M2-4656	M2-4656S	TCP, anatomical	4		1
M2-4658	M2-4658S	delta	4		1
M2-4660	M2-4660S		4	7 mm	1
M2-4662	M2-4662S		4	9 mm	1
M2-4664	M2-4664S		4	12 mm	1
M2-4692	M2-4692S	straight	6		1

TriLock Mandibular Angle Plates

Compatible with screws \varnothing 2.0/2.3/2.5

Material: Titanium (ASTM F67)
Plate thickness: 1.3 mm

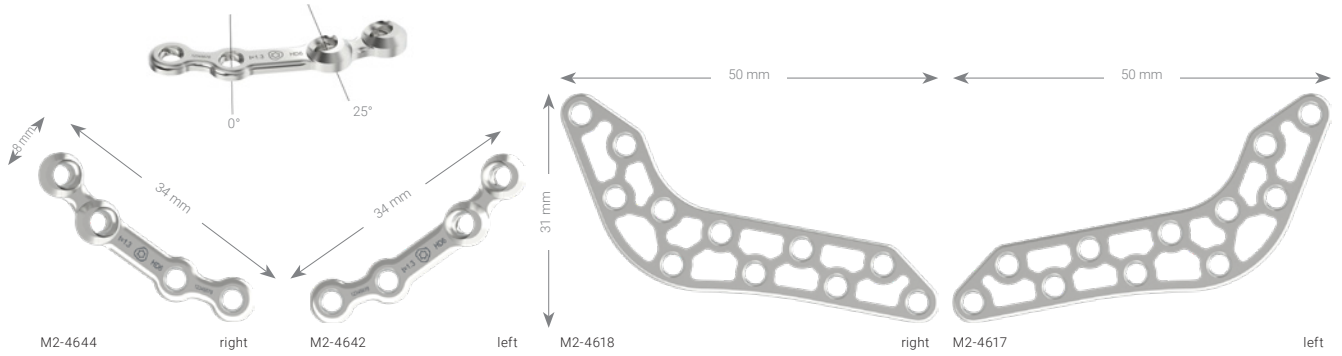

Art. No.	STERILE	Description	Holes	Pieces / Pkg
M2-4617	M2-4617S	Grid, left	11	1
M2-4618	M2-4618S	grid, right	11	1
M2-4642	M2-4642S	left	4	1
M2-4644	M2-4644S	right	4	1

TriLock Median-Paramedian Plates, Grid

Compatible with screws \varnothing 2.0/2.3/2.5

Material: Titanium (ASTM F67)
Plate thickness: 1.3 mm

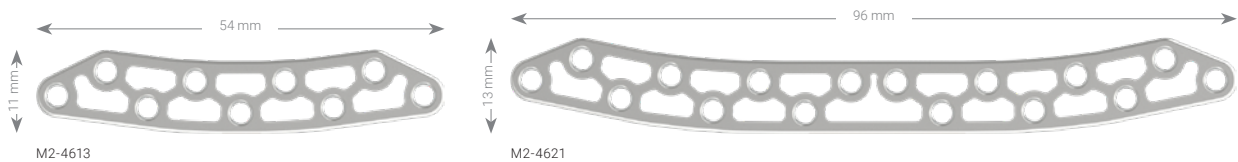

Art. No.	STERILE	Description	Holes	Pieces / Pkg
M2-4613	M2-4613S		9	1
M2-4621	M2-4621S		16	1

TriLock Pencilbone Plates, Grid

Compatible with screws \varnothing 2.0/2.3/2.5

Material: Titanium (ASTM F67)
Plate thickness: 1.3 mm

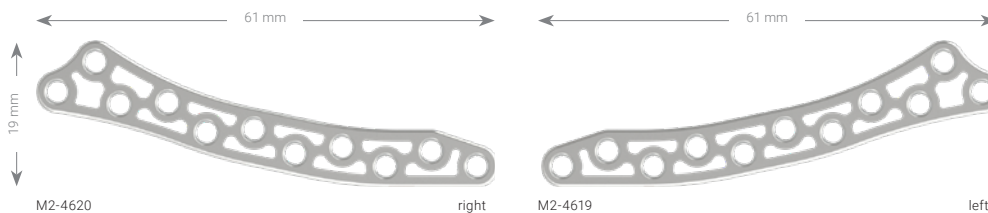

Art. No.	STERILE	Description	Holes	Pieces / Pkg
M2-4619	M2-4619S	left	11	1
M2-4620	M2-4620S	right	11	1

Mandible Plates t = 1.5 mm

TriLock Plates, Straight

Compatible with screws \varnothing 2.0/2.3/2.5

Material: Titanium (ASTM F67)
Plate thickness: 1.5 mm

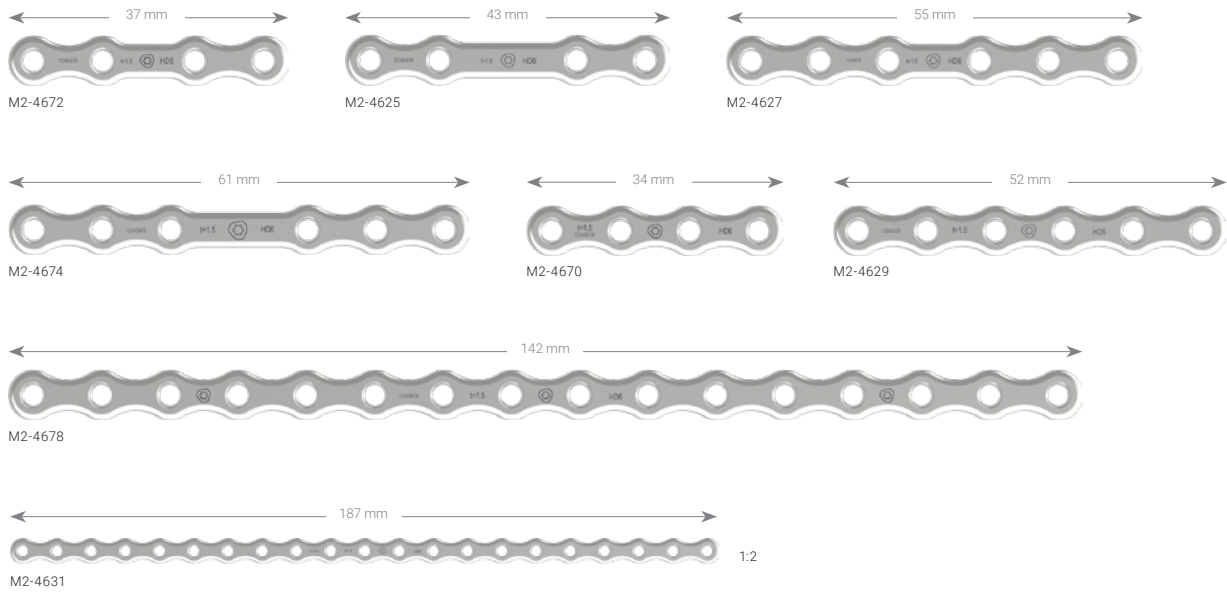

Art. No.	STERILE	Holes	Bar	Pieces / Pkg
M2-4625	M2-4625S	4	18 mm	1
M2-4627	M2-4627S	6	12 mm	1
M2-4629	M2-4629S	6		1
M2-4631	M2-4631S	21		1
M2-4670	M2-4670S	4		1
M2-4672	M2-4672S	4	12 mm	1
M2-4674	M2-4674S	6	18 mm	1
M2-4678	M2-4678S	16		1

TriLock Plates, Anatomical

Compatible with screws \varnothing 2.0/2.3/2.5

Material: Titanium (ASTM F67)
Plate thickness: 1.5 mm

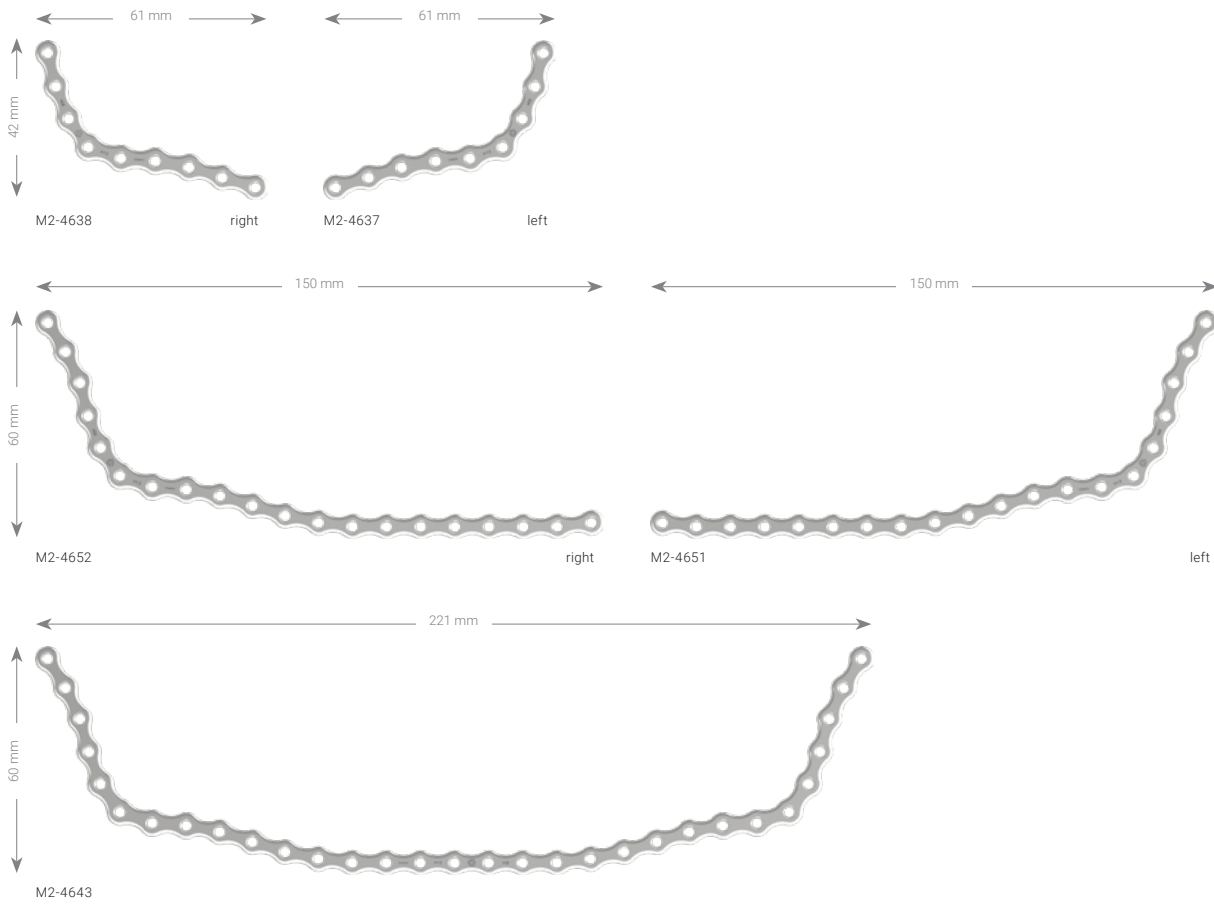

Art. No.	STERILE	Description	Holes	Pieces / Pkg
M2-4637	M2-4637S	left	9 (3+6)	1
M2-4638	M2-4638S	right	9 (3+6)	1
M2-4643	M2-4643S	LCL	31 (6+19+6)	1
M2-4651	M2-4651S	LC, left	20 (5+15)	1
M2-4652	M2-4652S	LC, right	20 (5+15)	1

Mandible TriLock Plates t = 2.0 mm

TriLock Bridging Plates

Compatible with screws \varnothing 2.0/2.3/2.5

Material: Titanium (ASTM F67)
Plate thickness: 2.0 mm

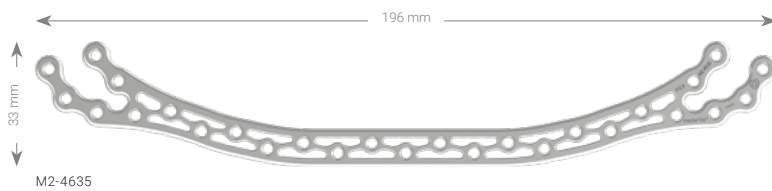
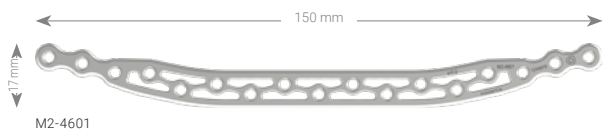
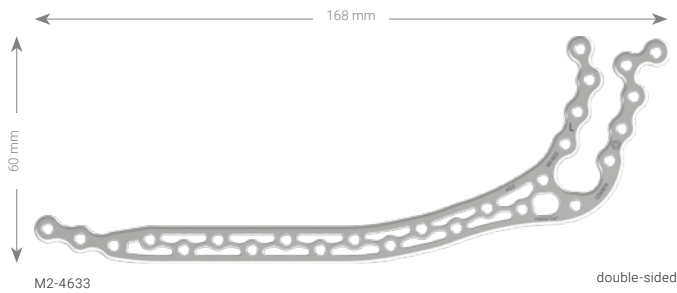
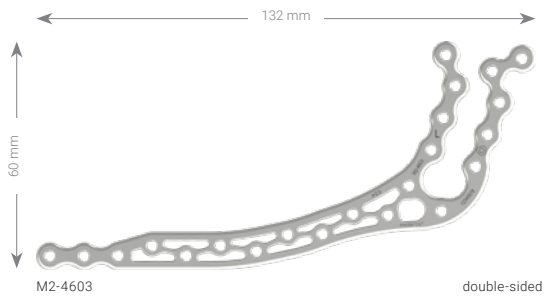

Art. No.	STERILE	Description	Holes	Pieces / Pkg
M2-4601	M2-4601S	C	17	1
M2-4603	M2-4603S	L/H, double-sided	22 (13+9)	1
M2-4633	M2-4633S	LC/HC, double-sided	26 (17+9)	1
M2-4635	M2-4635S	C, LCL	27 (5+17+5)	1

Templates for TriLock Bridging Plates

Material: Aluminum
Plate thickness: 1.0 mm

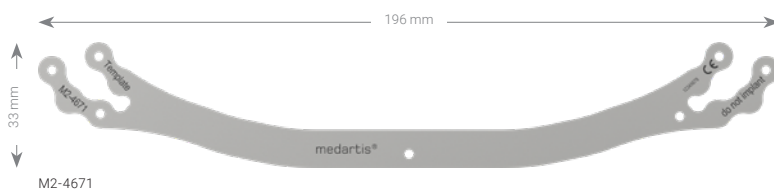
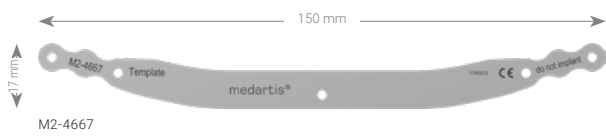
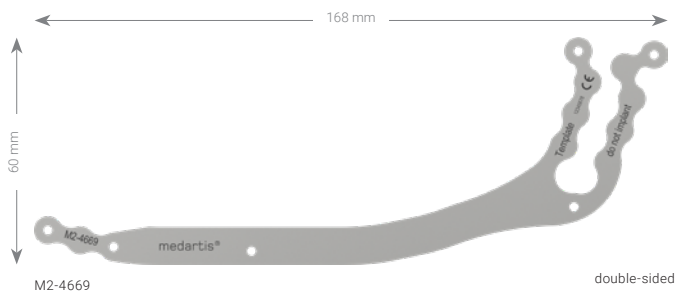
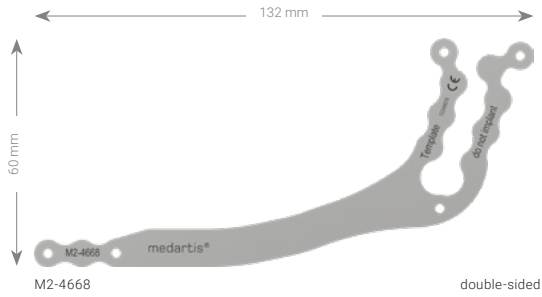

Art. No.	Description	Holes	Pieces / Pkg
M2-4667	for M2-4601	5	1
M2-4668	for M2-4603, double-sided	5	1
M2-4669	for M2-4633, double-sided	6	1
M2-4671	for M2-4635	7	1

C-Adaption for Bridging Plate

Compatible with connecting screw M2-5268.05S

Material: Titanium (ASTM F67)

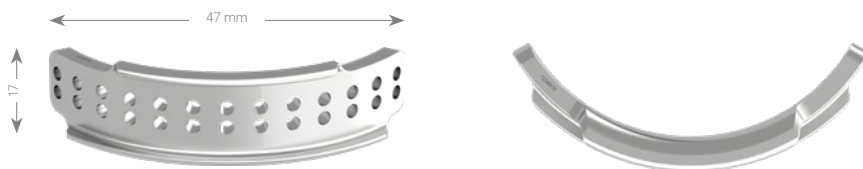

Art. No.	STERILE	Description	Pieces / Pkg
M2-4639S		left	1

Connecting Screw

Material: Titanium (ASTM F136)



Art. No.	STERILE	Description	Pieces / Pkg
M2-5268.05S		for M2-4639S, HD6	1

2.0 Cortical Screws, HexaDrive 6

Material: Titanium alloy (ASTM F136)

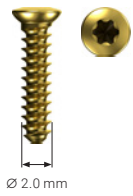

Length	Art. No.	STERILE	Pieces / Pkg	Art. No.	Pieces / Pkg
4 mm	M2-5240.04/1	M2-5240.04/1S	1	M2-5240.04	5
5 mm	M2-5240.05/1	M2-5240.05/1S	1	M2-5240.05	5
6 mm	M2-5240.06/1	M2-5240.06/1S	1	M2-5240.06	5
7 mm	M2-5240.07/1	M2-5240.07/1S	1	M2-5240.07	5
8 mm	M2-5240.08/1	M2-5240.08/1S	1	M2-5240.08	5
9 mm	M2-5240.09/1	M2-5240.09/1S	1	M2-5240.09	5
11 mm	M2-5240.11/1	M2-5240.11/1S	1	M2-5240.11	5
13 mm	M2-5240.13/1	M2-5240.13/1S	1	M2-5240.13	5
15 mm	M2-5240.15/1	M2-5240.15/1S	1	M2-5240.15	5
17 mm	M2-5240.17/1	M2-5240.17/1S	1	M2-5240.17	5
19 mm	M2-5240.19/1	M2-5240.19/1S	1	M2-5240.19	5

2.0 SpeedTip Screws, Self-Drilling, HexaDrive 6

Material: Titanium alloy (ASTM F136)

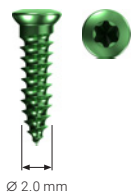

Length	Art. No.	STERILE	Pieces / Pkg	Art. No.	Pieces / Pkg
5 mm	M2-5243.05/1	M2-5243.05/1S	1	M2-5243.05	5
6 mm	M2-5243.06/1	M2-5243.06/1S	1	M2-5243.06	5
7 mm	M2-5243.07/1	M2-5243.07/1S	1	M2-5243.07	5
8 mm	M2-5243.08/1	M2-5243.08/1S	1	M2-5243.08	5
9 mm	M2-5243.09/1	M2-5243.09/1S	1	M2-5243.09	5
11 mm	M2-5243.11/1	M2-5243.11/1S	1	M2-5243.11	5

2.0 TriLock SpeedTip Screws, Self-Drilling, HexaDrive 6

Material: Titanium alloy (ASTM F136)

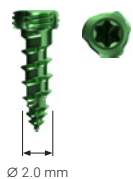

Length	Art. No.	STERILE	Pieces / Pkg	Art. No.	Pieces / Pkg
6 mm	M2-5247.06/1	M2-5247.06/1S	1	M2-5247.06	5
7 mm	M2-5247.07/1	M2-5247.07/1S	1	M2-5247.07	5
8 mm	M2-5247.08/1	M2-5247.08/1S	1	M2-5247.08	5

2.0 TriLock Screws, HexaDrive 6

Material: Titanium alloy (ASTM F136)



Length	Art. No.	STERILE	Pieces / Pkg	Art. No.	Pieces / Pkg
5 mm	M2-5245.05/1	M2-5245.05/1S	1	M2-5245.05	5
6 mm	M2-5245.06/1	M2-5245.06/1S	1	M2-5245.06	5
7 mm	M2-5245.07/1	M2-5245.07/1S	1	M2-5245.07	5
8 mm	M2-5245.08/1	M2-5245.08/1S	1	M2-5245.08	5
9 mm	M2-5245.09/1	M2-5245.09/1S	1	M2-5245.09	5
11 mm	M2-5245.11/1	M2-5245.11/1S	1	M2-5245.11	5
13 mm	M2-5245.13/1	M2-5245.13/1S	1	M2-5245.13	5
15 mm	M2-5245.15/1	M2-5245.15/1S	1	M2-5245.15	5

2.3 Cortical Screws, HexaDrive 6

Material: Titanium alloy (ASTM F136)



Length	Art. No.	STERILE	Pieces / Pkg	Art. No.	Pieces / Pkg
5 mm	M2-5250.05/1	M2-5250.05/1S	1	M2-5250.05	5
6 mm	M2-5250.06/1	M2-5250.06/1S	1	M2-5250.06	5
7 mm	M2-5250.07/1	M2-5250.07/1S	1	M2-5250.07	5
8 mm	M2-5250.08/1	M2-5250.08/1S	1	M2-5250.08	5
9 mm	M2-5250.09/1	M2-5250.09/1S	1	M2-5250.09	5
11 mm	M2-5250.11/1	M2-5250.11/1S	1	M2-5250.11	5
13 mm	M2-5250.13/1	M2-5250.13/1S	1	M2-5250.13	5
15 mm	M2-5250.15/1	M2-5250.15/1S	1	M2-5250.15	5
17 mm	M2-5250.17/1	M2-5250.17/1S	1	M2-5250.17	5
19 mm	M2-5250.19/1	M2-5250.19/1S	1	M2-5250.19	5

2.3 TriLock Screws, HexaDrive 6

Material: Titanium alloy (ASTM F136)



Length	Art. No.	STERILE	Pieces / Pkg	Art. No.	Pieces / Pkg
7 mm	M2-5255.07/1	M2-5255.07/1S	1	M2-5255.07	5
8 mm	M2-5255.08/1	M2-5255.08/1S	1	M2-5255.08	5
9 mm	M2-5255.09/1	M2-5255.09/1S	1	M2-5255.09	5
11 mm	M2-5255.11/1	M2-5255.11/1S	1	M2-5255.11	5
13 mm	M2-5255.13/1	M2-5255.13/1S	1	M2-5255.13	5
15 mm	M2-5255.15/1	M2-5255.15/1S	1	M2-5255.15	5
17 mm	M2-5255.17/1	M2-5255.17/1S	1	M2-5255.17	5
19 mm	M2-5255.19/1	M2-5255.19/1S	1	M2-5255.19	5

2.5 TriLock Screws, HexaDrive 6

Material: Titanium alloy (ASTM F136)



Length	Art. No.	STERILE	Pieces / Pkg	Art. No.	Pieces / Pkg
7 mm	M2-5265.07/1	M2-5265.07/1S	1	M2-5265.07	5
8 mm	M2-5265.08/1	M2-5265.08/1S	1	M2-5265.08	5
9 mm	M2-5265.09/1	M2-5265.09/1S	1	M2-5265.09	5
11 mm	M2-5265.11/1	M2-5265.11/1S	1	M2-5265.11	5
13 mm	M2-5265.13/1	M2-5265.13/1S	1	M2-5265.13	5
15 mm	M2-5265.15/1	M2-5265.15/1S	1	M2-5265.15	5
17 mm	M2-5265.17/1	M2-5265.17/1S	1	M2-5265.17	5
19 mm	M2-5265.19/1	M2-5265.19/1S	1	M2-5265.19	5

Twist Drills Ø 1.5 mm (Core Hole 2.0 Screws)

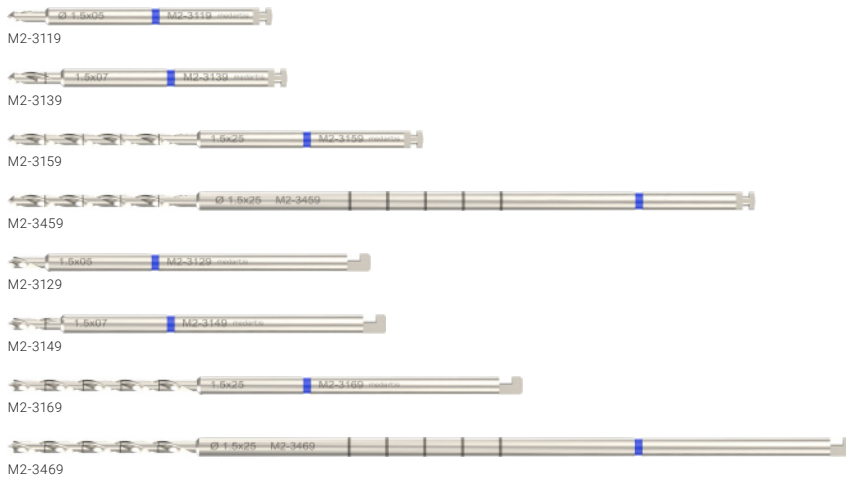

Art. No.	STERILE	Description	Stop	Length	Shaft End	Pieces / Pkg
M2-3119	M2-3119S		5 mm	35 mm	Dental	1
M2-3129	M2-3129S		5 mm	48 mm	Stryker J-Latch	1
M2-3139	M2-3139S		7 mm	37 mm	Dental	1
M2-3149	M2-3149S		7 mm	50 mm	Stryker J-Latch	1
M2-3159	M2-3159S		25 mm	55 mm	Dental	1
M2-3169	M2-3169S		25 mm	68 mm	Stryker J-Latch	1
M2-3459	M2-3459S	for drill guide M2-2198	25 mm	99 mm	Dental	1
M2-3469	M2-3469S	for drill guide M2-2198	25 mm	112 mm	Stryker J-Latch	1

Twist Drills Ø 2.0 mm (Gliding Hole 2.0 Screws)



Art. No.	STERILE	Description	Stop	Length	Shaft End	Pieces / Pkg
M2-3156	M2-3156S		25 mm	55 mm	Dental	1
M2-3166	M2-3166S		25 mm	68 mm	Stryker J-Latch	1
M2-3296	M2-3296S	for drill guide M2-2198	25 mm	99 mm	Dental	1
M2-3306	M2-3306S	for drill guide M2-2198	25 mm	112 mm	Stryker J-Latch	1

Twist Drills Ø 1.9 mm (Core Hole 2.3 Screws)



M2-3176



M2-3196



M2-3216



M2-3186



M2-3206



M2-3226

Art. No.	STERILE	Description	Stop	Length	Shaft End	Pieces / Pkg
M2-3176	M2-3176S		7 mm	37 mm	Dental	1
M2-3186	M2-3186S		7 mm	50 mm	Stryker J-Latch	1
M2-3196	M2-3196S		25 mm	55 mm	Dental	1
M2-3206	M2-3206S		25 mm	68 mm	Stryker J-Latch	1
M2-3216	M2-3216S	for drill guide M2-2198	25 mm	99 mm	Dental	1
M2-3226	M2-3226S	for drill guide M2-2198	25 mm	112 mm	Stryker J-Latch	1

Twist Drills Ø 2.3 mm (Gliding Hole 2.3 Screws)



M2-3316



M2-3336



M2-3326



M2-3346

Art. No.	STERILE	Description	Stop	Length	Shaft End	Pieces / Pkg
M2-3316	M2-3316S	for drill guide M2-2198	25 mm	99 mm	Dental	1
M2-3326	M2-3326S	for drill guide M2-2198	25 mm	112 mm	Stryker J-Latch	1
M2-3336	M2-3336S		25 mm	55 mm	Dental	1
M2-3346	M2-3346S		25 mm	68 mm	Stryker J-Latch	1

Twist Drill Ø 2.0 mm (Core Hole 2.5 Screws)



Art. No.	STERILE	Description	Stop	Length	Shaft End	Pieces / Pkg
M2-3236	M2-3236S		7 mm	37 mm	Dental	1
M2-3246	M2-3246S		7 mm	50 mm	Stryker J-Latch	1
M2-3256	M2-3256S		25 mm	55 mm	Dental	1
M2-3266	M2-3266S		25 mm	68 mm	Stryker J-Latch	1
M2-3276	M2-3276S	for drill guide M2-2198	25 mm	99 mm	Dental	1
M2-3286	M2-3286S	for drill guide M2-2198	25 mm	112 mm	Stryker J-Latch	1

Drill Guide

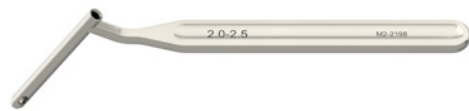

Art. No.	Size	Length	Pieces / Pkg
M2-2198	2.0-2.5	122 mm	

Depth Gauge



M2-2260

Art. No.	Size	Description	Length	Pieces / Pkg
M2-2260	2.0-2.5		160 mm	1

Screwdriver Handles



M2-2001



M2-2040

Art. No.	Description	Length	Pieces / Pkg
M2-2001	type 2 (hand driven small, AO coupling)	121 mm	1
M2-2040	type 3 (hand driven large, AO coupling)	115 mm	1

Screwdriver Blade



Art. No.	Interface	Description	Length	Pieces / Pkg
M2-2005	HD6	self-holding	95 mm	1

Plate and Screw Holding Forceps



M2-2009



M2-2019

Art. No.	Description	Length	Pieces / Pkg
M-2009	angled, small	150 mm	1
M-2019	angled, large	200 mm	1

Plate Cutting Pliers

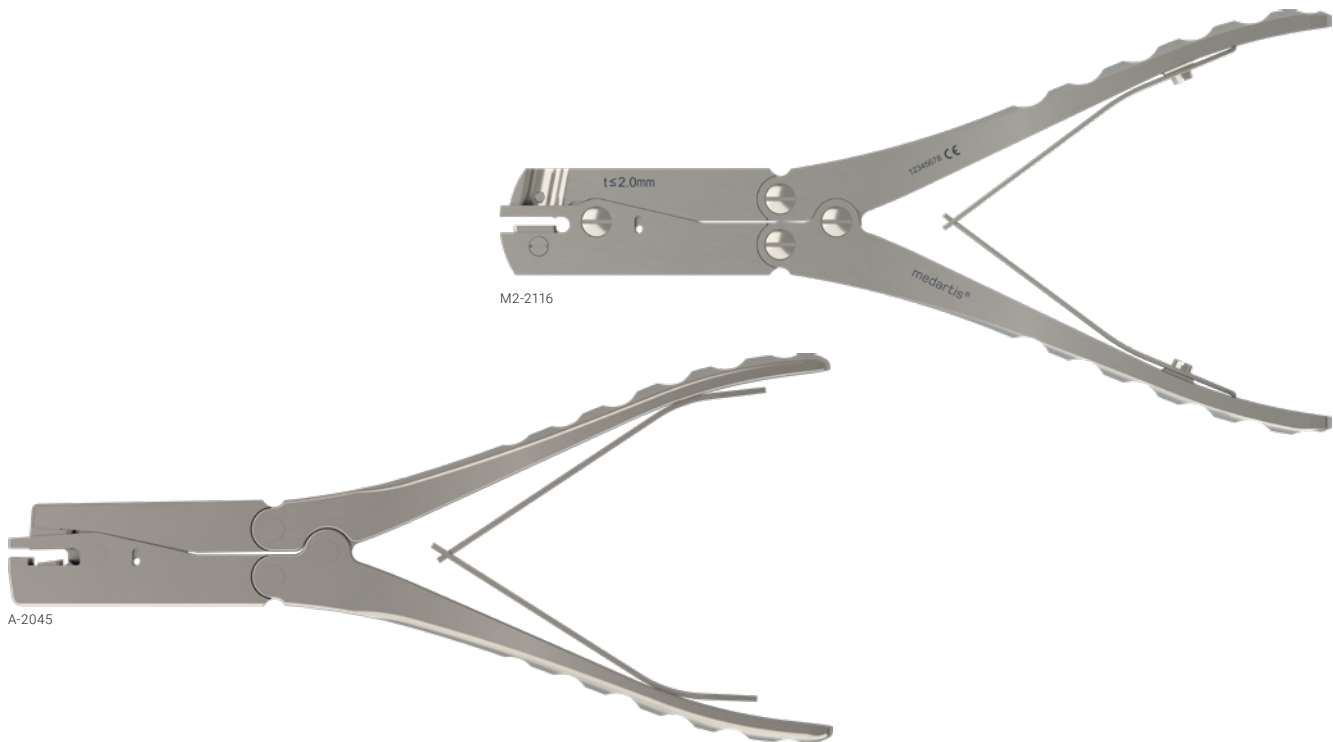

A-2045

Art. No.	Size	Description	Length	Pieces / Pkg
M2-2116		t ≤ 2.0 mm	220 mm	1
A-2045	2.0–3.5		218 mm	1

Bending Pliers

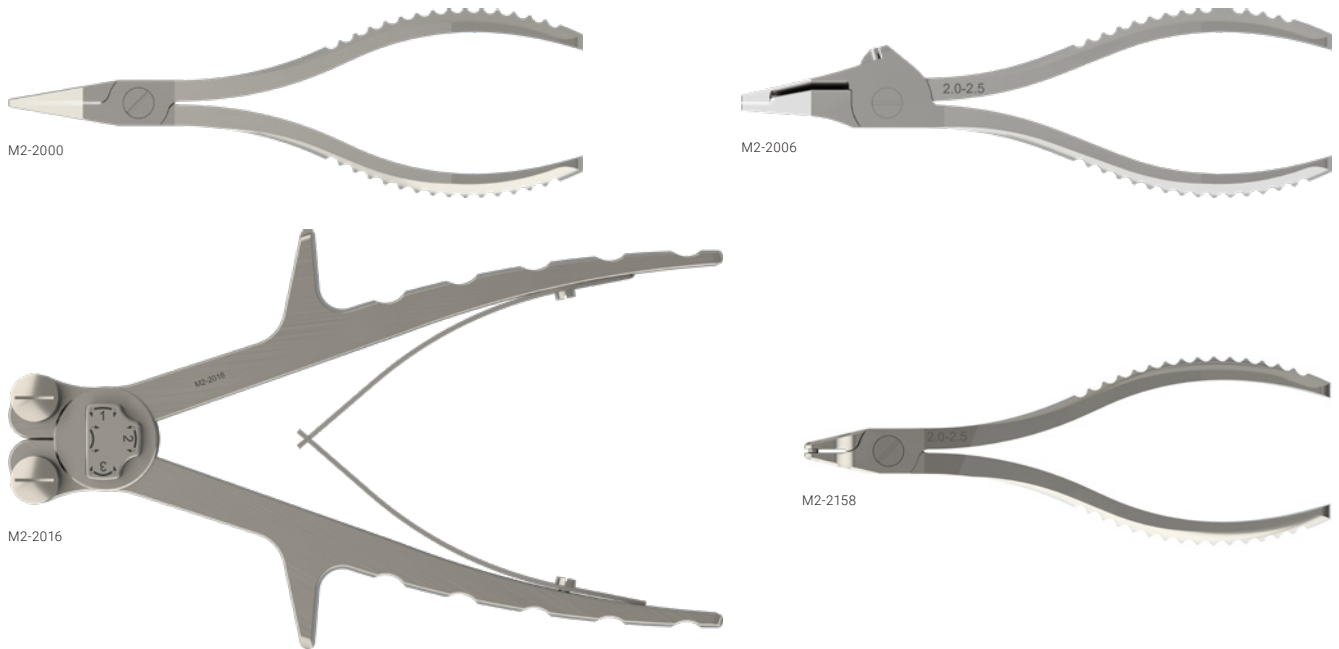

Art. No.	Size	Description	Length	Pieces / Pkg
M2-2000		flat	152 mm	1
M2-2006	2.0-2.5		156 mm	1
M2-2016	2.0-2.5	three-point bending pliers	189 mm	1
M2-2158	2.0-2.5	with pin	140 mm	1

Ramus Plate Bending Instrument



Art. No.	Length	Pieces / Pkg
M2-2026	125 mm	1

Temporary Locking Stopper



Art. No.	Length	Pieces / Pkg
M2-2007	24 mm	1

Containers

Plates

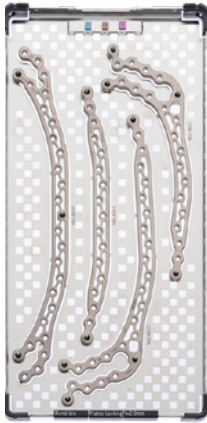

M2-6000.008
(excl. implants)



M2-6000.009
(excl. implants)



M2-6000.010
(excl. implants)

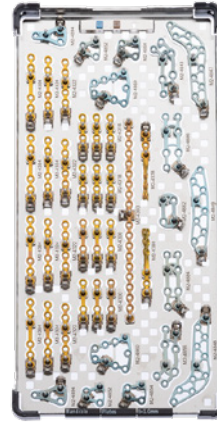

M2-6000.011
(excl. implants)



M2-6000.012
(excl. implants)

Art. No.	Description	Dimensions (W x L)	Pieces / Pkg
M2-6000.008	Implant Case, MANDIBLE, Plates, t2.0	120 x 240 mm	1
M2-6000.009	Implant Case, MANDIBLE, Plates, t1.5	120 x 240 mm	1
M2-6000.010	Implant Case, MANDIBLE, Plates, t1.3	120 x 240 mm	1
M2-6000.011	Implant Case, MANDIBLE, Plates, t1.0, Rigid	120 x 240 mm	1
M2-6000.012	Implant Case, MANDIBLE, Plates, t1.0, Semirigid	120 x 240 mm	1
M-6726	Lid f. Implant and Instr. Case 120 x 240 mm	120 x 240 mm	1

Screws

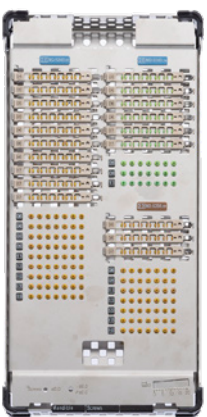

M2-6000.013
(excl. implants)

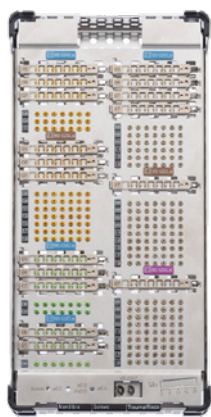

M2-6000.017
(excl. implants)

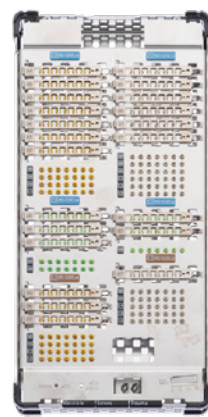

M2-6000.019
(excl. implants)

Art. No.	Description	Dimensions (W x L)	Pieces / Pkg
M2-6000.013	Implant Case, MANDIBLE, Screws 2.0/2.3	120 x 240 mm	1
M2-6000.017	Implant Case, MANDIBLE, Screws 2.0/2.3/2.5	120 x 240 mm	1
M2-6000.019	Implant Case, MANDIBLE, Screws 2.0/2.3	120 x 240 mm	1
M-6726	Lid f. Implant and Instr. Case 120 x 240 mm	120 x 240 mm	1

Instruments

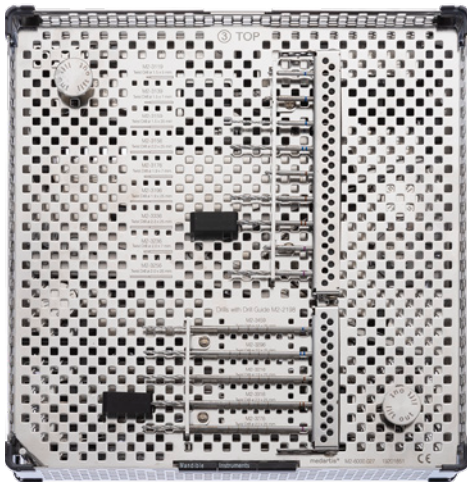

M2-6000.001 with M2-6000.005* / M2-6000.027*,
M2-6000.006 and M2-6000.007 (excl. instruments)

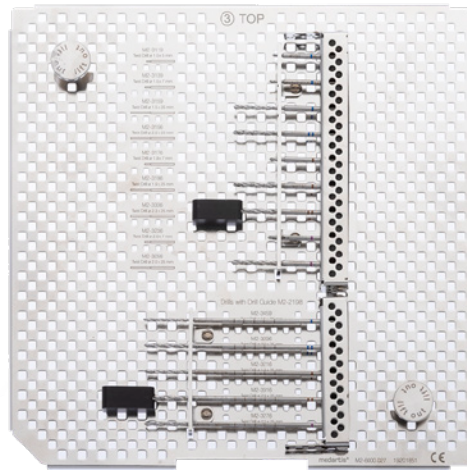

M2-6000.005* (excl. instruments)



M2-6000.006 (excl. instruments)

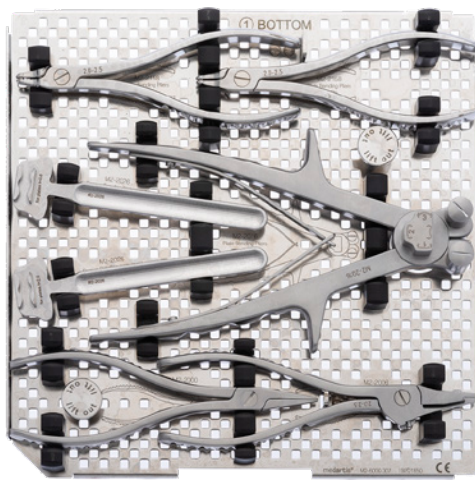

M2-6000.007 (excl. instruments)



M2-6000.021
(excl. instruments)

Art. No.	Description	Dimensions (W x L)	Pieces / Pkg
M2-6000.001	Instrument Case, MANDIBLE	240 x 240 mm	1
M2-6000.005*	Instrument Tray, MANDIBLE, 3, Stryker	240 x 240 mm	1
M2-6000.027*	Instrument Tray, MANDIBLE, 3, Dental	240 x 240 mm	1
M2-6000.006	Instrument Tray, MANDIBLE, 2	240 x 240 mm	1
M2-6000.007	Instrument Tray, MANDIBLE, 1	240 x 240 mm	1
M-6727	Lid f. Implant and Instr.Case 240 x 240 mm	240 x 240 mm	1
M2-6000.021	Instrument Case, MANDIBLE, Templates	120 x 240 mm	1
M-6726	Lid f. Implant and Instr.Case 120 x 240 mm	120 x 240 mm	1

Additional configurations available on request.

* Choose between Stryker or Dental Instrument Tray based on drill coupling

R_MANDIBLE2-01010001_v2 / © 2023-01, Medartis AG, Switzerland. All technical data subject to alteration.

MANUFACTURER & HEADQUARTERS

Medartis AG | Hochbergerstrasse 60E | 4057 Basel / Switzerland
P +41 61 633 34 34 | F +41 61 633 34 00 | www.medartis.com

SUBSIDIARIES

Australia | Austria | Brazil | France | Germany | Japan | Mexico | New Zealand | Poland | Spain | UK | USA

For detailed information regarding our subsidiaries and distributors, please visit www.medartis.com



Disclaimer: This information is intended to demonstrate the Medartis portfolio of medical devices. A surgeon must always rely on her or his own professional clinical judgement when deciding whether to use a particular product when treating a particular patient. Medartis is not giving any medical advice. The devices may not be available in all countries due to registration and/or medical practices. For further questions, please contact your Medartis representative (www.medartis.com). This information contains products with CE and/or UKCA marking. All pictures shown are for illustration purposes only and may not be an exact representation of the product. For US only: Federal law restricts this device to sale by or on the order of a physician.